



Electromagnetic Technology



MAGNETTECHNIQUE

More than 30 years experience in the field of Electromagnetic technology

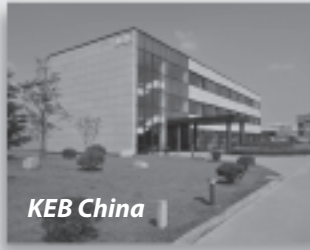

All our efforts are directed towards the development, production and application of electromagnetic technology throughout our extensive range of brakes and clutches.

The functions, starting, stopping, positioning and safe holding of moving axes in machines and plant call for reliably designed and safely functioning components. With our advanced manufacturing techniques we are able to produce high quality, high-grade products, and through our continued investment we now have manufacturing plants world-wide. We have the ability to produce high volume stock parts or ones that are tailored specifically to your requirements.

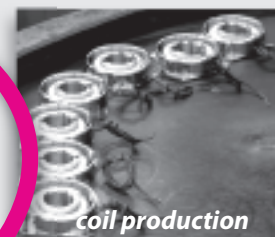
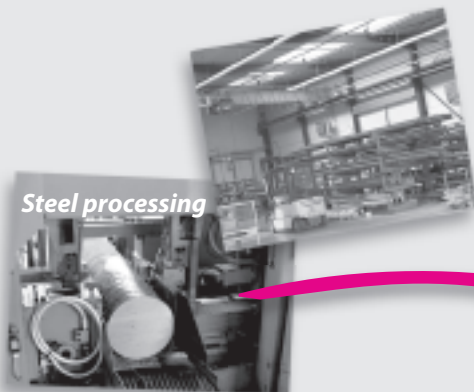

Safe braking and holding

COMBISTOP H



COMBISTOP N

COMBISTOP D



COMBISTOP T



COMBISTOP

Electromagnetically actuated dual-surface spring applied DC brakes for dry operation.
... starting from page 4

COMBIPERM

Permanent magnet fail-safe brakes and clutches for dry operation.
... starting from page 16

COMBIPERM P1



COMBIPERM P1



COMBIPERM 22



SWITCHING, STOPPING, POSITIONING

COMBINORM

electromagnetic-actuated open-circuit operated clutches and brakes without slip rings.
... starting from page 22

COMBINORM C



COMBINORM B



COMBINORM K



COMBIBOX



COMBIBOX

a ready to be installed electromagnetic- actuated clutch-brake-module
... starting from page 36

POWER SUPPLY / SWITCHGEAR

COMBITRON

DC-supply from the alternating voltage supply system and electronic switches for electromagnetic clutches and brakes.
... starting from page 44

COMBITRON 91



COMBITRON 98



COMBITRON 94



COMBISTOP are electromagnetically actuated dual surface spring-applied DC brakes for dry application. The braking force is applied by the springs and released through the electromagnetic force. These brakes are successfully working in the most demanding applications and are used wherever rotating masses must be stopped or shafts need to held in a precise position.

High quality materials together with high precision manufacturing, process inspections and functional testing guarantee reliable, safe operation.

On request we can design the **COMBISTOP** brake to your requirements, for example the brake can be supplied with pre-mounted armature and increased torque.

Program Schedule

COMBISTOP Electromagnetically actuated dual-surface spring applied DC brakes

Mini brakes 0,3 ... 2 Nm	page 5	COMBISTOP M
Holding brake for dynamic demands 2 ... 1.000 Nm	page 6	COMBISTOP N
Holding brake for static application 5 ... 1.500 Nm	page 6	COMBISTOP H
Holding brake for protection class IP 66 4 ... 400 Nm	page 8	COMBISTOP P
Holding brake for tacho mounting 4 ... 250 Nm	page 8	COMBISTOP T
Double-brake for theatre, lift and elevators 2 x 5 ... 2 x 1000 Nm	page 10	COMBISTOP D
Hoisting brakes, elevator brakes D8 2 x 25 ... 2 x 125 Nm	page 10	COMBISTOP L
Accessories	page 12	

Technical data

switching times	page 15
dimensioning / calculation	page 50
Legend	page 51

Accessories

COMBISTOP	M	N	H	P	T	D	L
friction disc		X	X			X	X
flange	X	X	X	X	X	X	X
friction disc with collar				X			
dust protection ring		X				X	
micro switch		X	X			X	X
hand release	X	X	X	X	X		X
terminal box		X	X	X	X	X	X

COMBISTOP M

stands for MINI Brake, the small compact solution with torques up to 2 Nm. The brake is characterized by a particular compact construction, it is designed for small loads and holding functions without torque adjustment and adjustability and available with or without hand release.

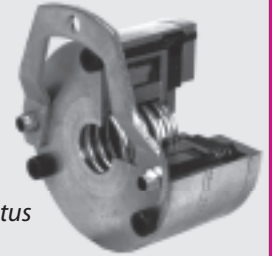

Range of application: e.g. general machine building, small-power motors, automation technique, apparatus engineering.

COMBISTOP M

0B.08.110... without hand release

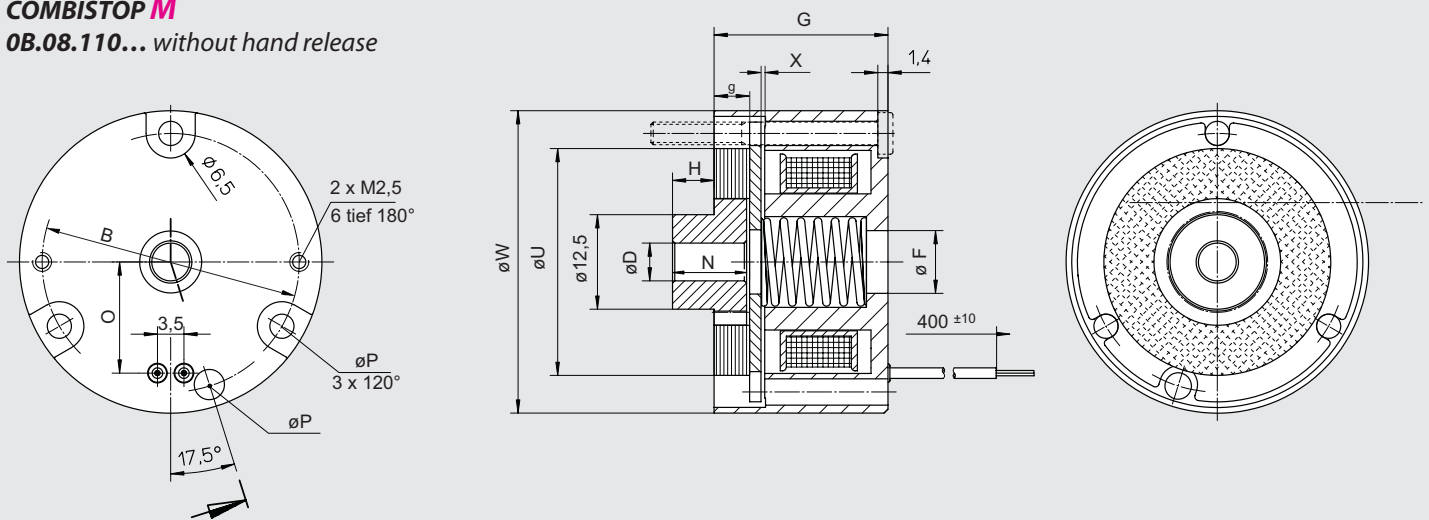

size	$M_{2N}^{1)}$ [Nm]	P_{20} [W]	A	B	D	F	G	H	K	N	O	P	T	U	V	W	X	a_1	b_1	c	e	g	$m^3)$	α°	weights [kg]
0B.08	0.3	6		34	5	8,3	23	5,5		9,8	14,7	3,5		30	40	0,1						4,7			0,15
00.08	0.5-2	11-15	59,5	52	10 ²⁾	14	29,5	0,5-1	4,5	16	18	4,3	5	43,5	26	59,5	0,15	41	36,5	2	7	5,5	0,8	7	0,4

All dimensions in mm keyway according to DIN 6885/1 according to VDE 0580, isolation class „B“ ¹⁾ rated torque after running in process ²⁾ bore tolerance max $\phi 10$ mm H7, otherwise H8
³⁾ Mounting dimension „m“ with attracted armature

COMBISTOP M

00.08.110... without hand release
 00.08.130... with hand release

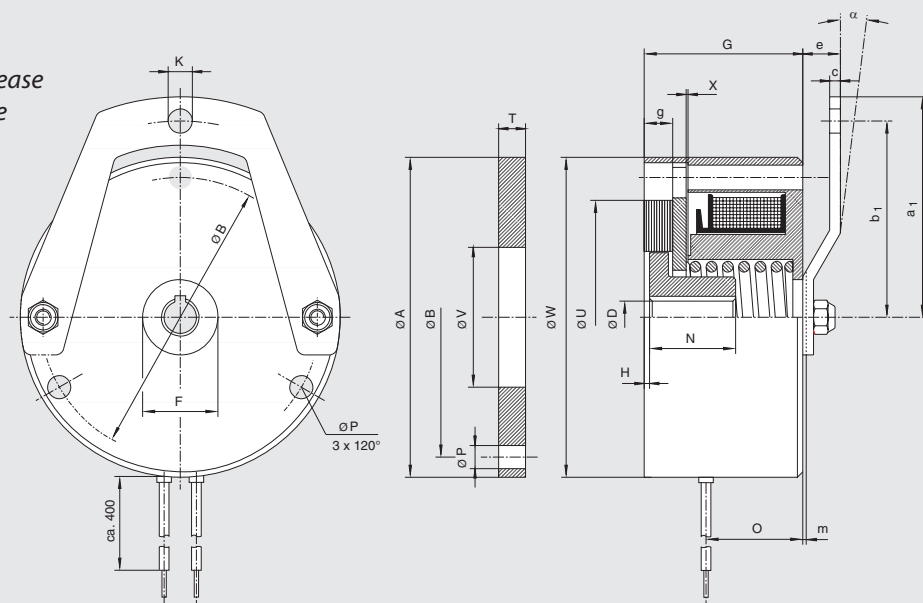

Accessories **COMBISTOP M:**

- flange

COMBISTOP

COMBISTOP **N** and **H**

are the standard series of dual-surface spring-applied brakes in two designs:

- dynamic applications with continuous stress
- static applications with short-term stress

COMBISTOP N
COMBISTOP H

COMBISTOP N: Rated torque in the range 5 ... 1000 Nm - designed for dynamic applications with regular brake applications at high speed!

Range of application: e.g. brake motors, geared brake motors, wind energy plants, refrigerated warehouses

- Option:**
- Cold Climate Version CCV (-40 ... +60° C)
 - ISO-class F + H

Accessories **COMBISTOP N:**

- friction disc
- flange
- friction disc with collar (up to size 06)
- dust protection ring
- micro switch
- terminal box

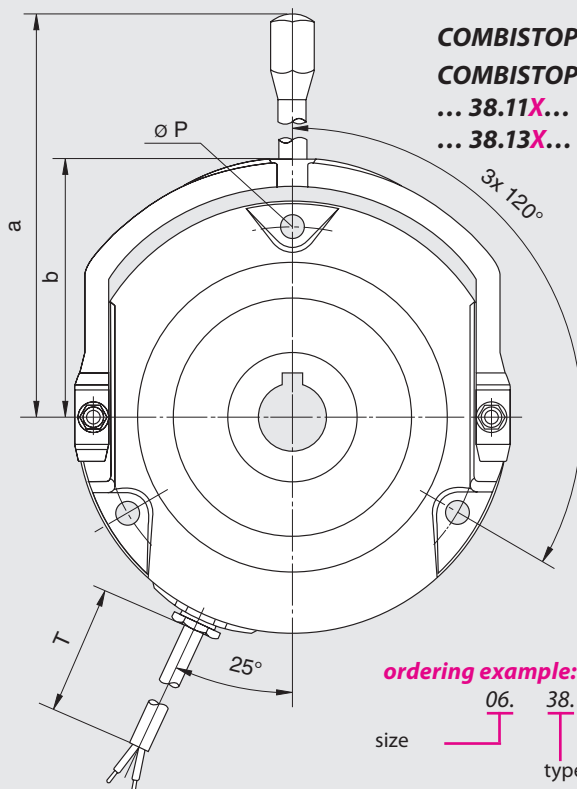

COMBISTOP N - dynamic operation

COMBISTOP H - static operation

... 38.11X...

without hand release

... 38.13X...

with hand release

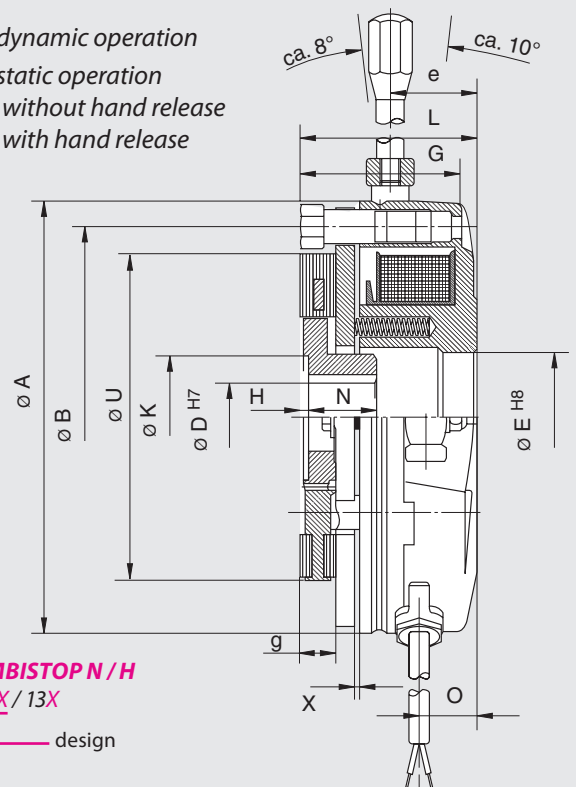

ordering example: **COMBISTOP N / H**

size 06 38 11X/13X
 type
 V DC, Ø D ?

size	version „N“		version „H“		A	B	H7 Ø D max.	E	G	H	K	L	N	O	P	T	U	X	a	b	e	g	weight kg
	M _{2N} ¹⁾	P ₂₀	M _{2N} ¹⁾	P ₂₀																			
	Nm	W	Nm	W																			
02	5	25	7.5	25	85	72	15**	22	34.2	1-1.5	22	37.7	18	11.5	3x4.5	500	60	0.2	105.5	53.5	23	7.5	1
03	10	30	15	30	102	90	20	32	37.2	2-2.5	31	41.7	20	13	3x5.5	500	77	0.2	113	62	25.5	8	1.5
04	20	30	30	30	127	112	25	38	47.2	2-2.5	37	51.7	20	16.5	3x6.5	500	96	0.2	128	76	26.2	10.5	3
05	36	48	50	48	147	132	30	42	52.7	2.5-3	42	57.7	25	18.5	3x6.5	500	115	0.2	168	86	30.5	12	4.5
06	70	62	90	75	164	145	35**	47	59.8	2.5-3	42	68.8	30	20	3x9	500	115	0.3	176	96	39.5	12	7
07	100	65	150	90	190	170	45	62	68	3	57	75.5	30	21.5	3x9	750	149	0.3	225	115	41	14	10
08	150	75	225	90	218	196	60	78	80	4.5	57/76*	87.4	35	27	3x9	750	175	0.4	235	125	46.5	16	16
09	250	80	375	115	253	230	60	97	88.2	5	76	101.7	40	28	3x11	750	206	0.4	256	146	56	18	26
10	500	130	750	180	307	278	75	120	98.8	9.5	92	110.8	50	25	6x11	750	252	0.5	335	175	59	22	39
11	1000	180	1500	280	363	325	90	140	122.1	-	-	134.5	100	30.5	6x11	1000	300	0.6	***	***	***	30	80

All dimensions in mm keyway according to DIN 6885/1 Standard voltage 24 / 105 / 180 / 205 V DC according to VDE 0580, isolation class „B“, 100% on time, Type of protection IP40, with dust protection ring IP44
¹⁾ rated torque after running in process * hub bore > ø 45 ** keyway according to DIN 6885/3 *** mech. release with hexagon screw

COMBISTOP N and H

COMBISTOP H:

Rated torque in the range 7.5 ... 1500 Nm - designed for static applications, i.e. braking from low speeds and secure holding of loads!

Range of application:

e.g. electronically controlled or regulated drives, wind energy plants, refrigerated warehouses



Accessories COMBISTOP H:

- friction disc
- flange
- friction disc with collar (up to size 06)
- dust protection ring
- micro switch
- terminal box



COMBISTOP T

Two brakes designs which are always used whenever the application puts higher demands on the protection class.

COMBISTOP T: the IP 65-brake with identical hole circle such as **COMBISTOP N** and **H**, optionally completely closed prepared for the attachment of tacho-generators (xx.28.GxT) or shaft sealing ring.

Range of application: e.g. general machine building, crane construction, ship gear, wind energy plants, refrigerated warehouses

size	M _{2N} ¹⁾ [Nm]	P ₂₀ [W]	øA ₁	øA h8 H8	øB	C	øD max.	øE	øE ₁	øF	øG	H	øK	L	M	M ₁	N	O	øP	øP ₁	øP ₂	R	T	øV
02	4	20	102	98	72	34	15**	50	85	94.5	88	1-1.5	22	37.5	2.4	88x3	18	11	4.5	8	M4	0.5	6	37
03	8	25	123	118	90	37	20	64	102	116	109.5	2-2.5	31	41.1	2.4	110x3	20	12.5	5.6	10	M5	1.5	7	48
04	16	30	148	143	112	47	25	80	127	138.5	132	2-2.5	37	51.1	2.4	132x3	20	16	6.5	11	M6	1.5	9	60
05	32	40	170	165	132	51.5	30	102	147	158.5	152	2.5-3	42	56.1	2.4	152x3	25	17	6.5	11	M6	2	9	70
06	60	52	186	180	145	60	35**	115	164	176.5	170	2.5-3	42	66.5	2.4	170x3	30	20	9	15	M8	2	11	70
07	100	65	216	210	170	68	45	144	193	200.5	196	2.0	57	74	3.5	196x4	30	20	9	15	M8	3.0	12	75
08	150	75	246	240	196	77	60	160	217	235.5	225	4.5	⁵⁷ / ₇₆ *	86.5	3.2	225x4	35	25	9	15	M8	3.5	14	95
09	250	75	280	240	230	86	60	180	254	272	260	5.0	76	102	3.5	260x5	40	33	11	18	M10	4.0	15	95

all dimensions in mm keyway according to DIN 6885/1 standard voltage 24/105/180/205 V DC according to VDE 0580, ISO-class „B“, 100% on time, ¹⁾ Nennmoment nach Einlauf ¹⁾ rated torque after running in process * hub bore > ø 45 ** keyway according to DIN 6885/3, Attention: Unter den Befestigungsschrauben sind Dichtscheiben (DIN7603) zu verwenden

Accessories **COMBISTOP T:**

- flange
- terminal box
- hand release
- shaft sealing ring



COMBISTOP P:

completely closed version in protection class IP 66 with sealing of the mounting side and electrical connection, optionally with internally running connecting cable or attached terminal box.

Range of application: e.g. general machine building, crane construction, ship gear, wind energy plants, refrigerated warehouses

size	M _{2N} ¹⁾ [Nm]	P ₂₀ [W]	øA	øB	H7 øD max.	øE	øF	øG	H	øK	L	M	M ₁	N	O	R	S	S ₁	sw	T	T ₁	øV	øV ₁	W
02	4	20	108	100	15**	50	94	88	1-1.5	22	38	2.4	88x3	18	13.5	2	4.5	8	11	6	6	20	37	43
03	8	25	138	125	20	64	116.5	110	2-2.5	31	42.2	2.4	110x3	20	14	2	6.5	8	11	7	7	40	48	57.5
04	16	30	160	148	25	80	139	132	2-2.5	37	51.2	2.4	132x3	20	16	2	6.5	8	11	8.5	9	40	61	68
05	32	40	190	175	30	102	163	154	2.5-3	42	56.2	3.5	155x4	25	17	2	8.5	10	14	9	10	47	71	82
06	60	52	200	185	30	115	173	164	2.5-3	42	66.5	3.5	164x4	30	20	2	8.5	10	14	10	11	55	71	87
07	100	65	238	220	45	144	206	196	3	57	74	3.2	196x4	30	20	-	11	14	17	12	12	75	-	100
08	150	75	268	250	60	160	235	225	4.5	⁵⁷ / ₇₆ *	86.5	3.2	225x4	35	27	-	11	14	17	14	14	95	-	114
09	250	75	312	290	60	180	272	260	5	76	102	4	260x5	40	33	-	14	14	17	15	15	95	-	131.5
10	400	130	362	340	75	230	322	310	9.5	92	110	4	310x5	50	35	-	14	16	19	15	15	120	-	158

all dimensions in mm keyway according to DIN 6885/1 standard voltage 24 / 105 / 180 / 205 V DC according to VDE 0580, ISO-class „B“, 100% on time, ¹⁾ Nennmoment nach Einlauf ¹⁾ rated torque after running in process * hub bore > ø 45 ** keyway according to DIN 6885/3

COMBISTOP T
...28.GXX...

... on the backside or

... arehouses

X	a ₁	b ₁	ød	e	sw	øf	øg	s	k	L1	l
0.2	105.5	53.5	8	22.5	11	25	34	4xM4	10	36.5	44
0.2	114	62	8	24	11	32	40	4xM5	12	40.1	52
0.2	128	76	8	25.7	11	42	54	4xM5	12	50.1	66
0.2	166	86	10	28	14	50	64	4xM5	12	56.1	76
0.3	176	96	10	40	14	60	75	4xM5	12	65.5	88
0.3	225	115	14	40	17	68	85	4xM6	15	73	100
0.4	235	125	14	45	17	80	100	4xM6	15	86	120
0.5	256	145	14	40	17	80	110	4xM6	15	101	130

see dimension diagram 28.M01-3-0031

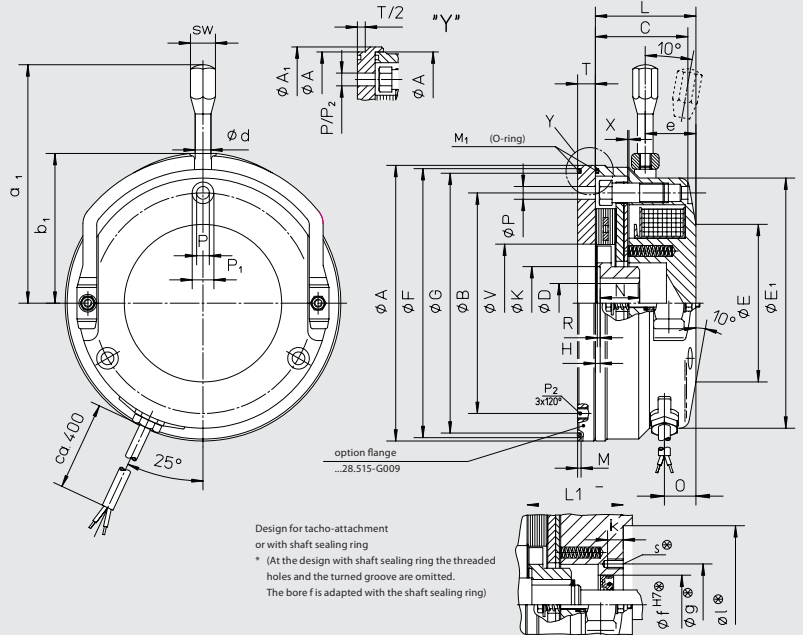

Design for tacho-attachment or with shaft sealing ring
* (At the design with shaft sealing ring the threaded holes and the turned groove are omitted. The bore f is adapted with the shaft sealing ring)

- Option:**
- Cold Climate Version CCV (-40 ... +60° C)
 - ISO-class F + H

COMBISTOP P

Accessories **COMBISTOP P:**

- flange
- terminal box
- hand release

- Option:**
- Cold Climate Version CCV (-40 ... +60° C)
 - ISO-class F + H

Bestellbeispiel: COMBISTOP T / P

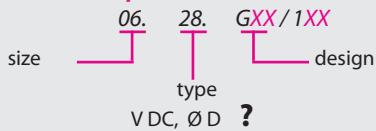

COMBISTOP P
....28.1XX...

X	a	a ₁	b	α
0.2	105.5	79	36	10°
0.2	113	93.5	40	10°
0.2	128	104	49	10°
0.2	166	118	55	10°
0.3	176	123	74	15°
0.3	225	136	74	15°
0.4	235	150	76,5	15°
0.5	256	168	92	15°
0.5	335	194	101	15°

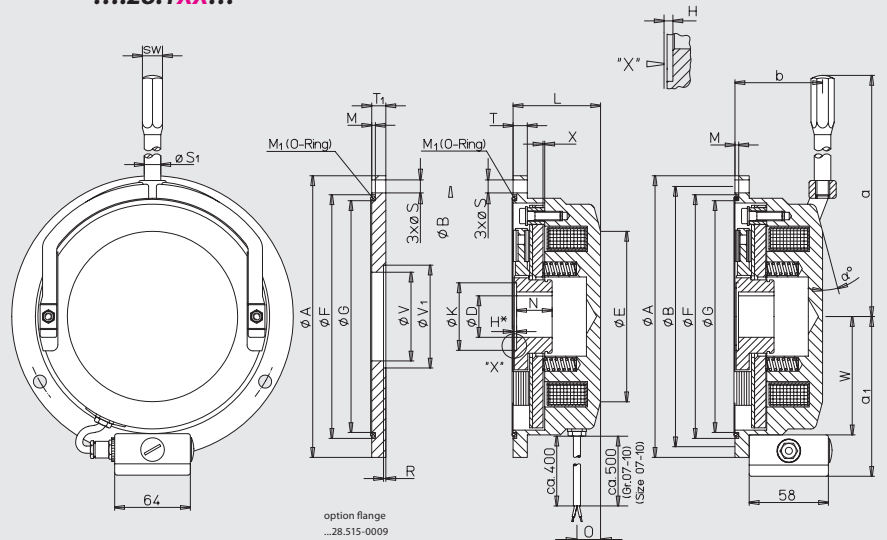

option flange ...28.515-0009

COMBISTOP D

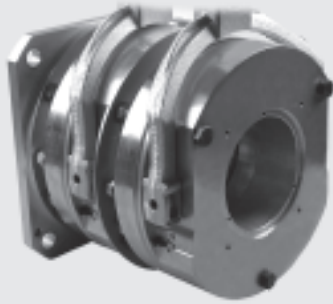

stands for **double safety** and covers a series of double brakes, which is prepared for tasks with redundant brake circuits.

The mechanical construction with two completely independent fail-safe spring-applied brakes meets the requirements according to DIN 56950 (BGV C1).

The brakes are supplied ex factory, ready for attachment with preadjusted air gaps.

Extensive constructional measures reduce the switching and running noises to a minimum.

size	M _{2N} ¹⁾ (Nm stat)	P ₂₀ (W)	A	B	C	1 & 2 D (max)	E	F	H	L ₁	L ₂	M	N ₁	N ₂	R ₁	T	X	a	b	e ₁
02	2x5	2x25	85	72	22	15**	22	36	91.2	9.5	1.5	18	27.5	13	8	500	0.2	105.5	53.5	45.5
03	2x10	2x30	102	90	32	20	31	48	106	12.5	2.5	20	34	17	10	500	0.2	114	62	54
04	2x20	2x30	127	112	38	25	37	60	121	12.5	2.5	20	39	23	10	500	0.2	128	76	65
05	2x36	2x48	147	132	42	30	42	70	135	14	3	25	41	21	11	500	0.2	168	86	72
06	2x70	2x62	164	145	47	35**	42	70	157	16	3	30	45	20	13	500	0.3	176	96	81
07	2x100	2x65	190	170	62	45	57	75	180	18.5	3	30	59	37	15	750	0.3	225	115	94
08	2x150	2x75	218	196	78	60	57/76*	100	193	19.5	5	35	55	33	14.5	750	0.3	235	125	97
09	2x250	2x80	254	230	97	60	76	100	224	22	5.5	40	65	45	16.5	750	0.3	256	146	107
10	2x500	2x130	306	278	120	75	92	120	241	27	10	50	63	36	17	750	0.4	335	175	121
11	2x1000	2x180	upon request																	

all dimensions in mm keyway according to DIN 6885/1 standard voltage 24 / 105 / 180 / 205 V DC according to VDE 0580, ISO-class „B“, 100% on time,
¹⁾ rated torque after running in process * hub bore > ø 45 ** keyway according to DIN 6885/3

As special development for the elevator industry the dual-circuit spring-applied fail-safe brake fulfills the valid requirements of EN 81 respectively TRA 227.

The brake series, tested by the technical inspection authority, contains two mechanical braking circuits and offers compact dimensions and easy mounting.

Range of application: e.g. passenger and freight elevators, theatre equipment

Option: ISO class F + H

Accessory **COMBISTOP L** :

- friction disc
- flange
- micro switch
- terminal box

size	2 x M _{2N} ¹⁾ (Nm stat.)	P ₂₀ (W)	H							L						
			A	B	C	D ^{H7}	E	F	G	D8.230	D8.630	D8.230	D8.630	N	O	X _n
05	25	60	154	146	132	30	42	65	147	3	3	53.8	54.3	25	19.5	0.3
07	50	65	203	188	170	40	57	65	190	3	3	74.3	74.3	30	20	0.4
09	125	75	268	230	230	60	76	101	254	5	5	98.7	98.7	40	20	0.5

size	a	b	d	e		l	m	P ₁ * ISO 4762	P ₂ * ISO 4762	P ₃ * ISO 4762	2 x X _v D8.630	SW	α°	δ°
				D8.230	D8.630									
05	169	89	10	34.8	35.3	2.5	1.2	M6x65	M6x10	M5x40	0.15	14	10	28
07	225	115	14	33.5	33.5	2.5	1.3	M8x80	M8x12	M6x50	0.20	17	10	25
09	255	145	14	65.7	65.7	3.0	1.4	M10x100	M10x16	M8x75	0.25	17	10	25

all dimensions in mm keyway according to DIN 6885/1 standard voltage 24 / 105 / 180 / 205 V DC according to VDE 0580, ISO-class „B“, 100% on time,
¹⁾ hub bore > ø 45 ** keyway according to DIN 6885/3 see dimension diagram D8.M01-4-0707

Range of application:

e.g. theatre equipment, passenger and freight elevators

Option: ISO class F

ordering example: COMBISTOP D

size 06. 38. DDN design
 type
 VDC, $\emptyset D_1$, $\emptyset D_2$?

Fastening Screws

e_2	d_1	d_2	m	Z 1/2/3	Z_1	Z_2	Z_3
22.5	34.6	39	0.8	M4	3x8.8	3x8.8	3x8.8
27	37.7	47.5	1	M5	3x8.8	3x8.8	3x8.8
31	47.8	54.4	1.4	M6	3x8.8	3x8.8	3x8.8
33	53.4	55.9	1.5	M6	3x10.9	3x8.8	3x8.8
36	60.3	64.5	1.8	M8	3x10.9	3x8.8	3x8.8
45	68.8	77.6	2	M8	6x8.8	3x8.8	3x8.8
50	80.8	82.7	2	M8	6x10.9	3x10.9	3x10.9
56	89.4	95.4	2.3	M10	6x8.8	3x10.9	3x10.9
61	99.5	105	2.7	M10	6x10.9	6x8.8	3x8.8

see dimension diagram 38.003-3-0714

COMBISTOP D

...38.DDN...

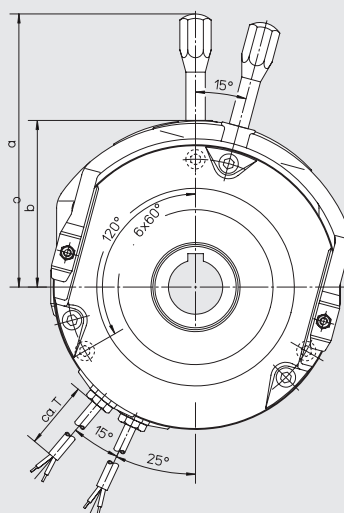

hub variation 1

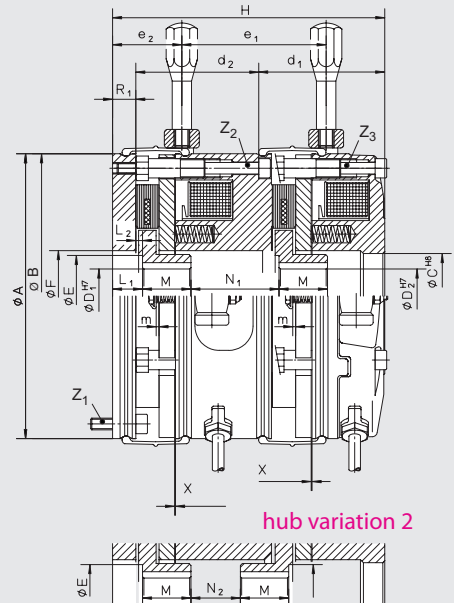

Accessories COMBISTOP D:

- friction disc
- dust protection ring
- micro switch
- flange
- terminal box
- friction disc with collar (up to size 06)

COMBISTOP L

ordering example: COMBISTOP L

size 05. D8. 230/630 design
 type
 VDC, $\emptyset D$?

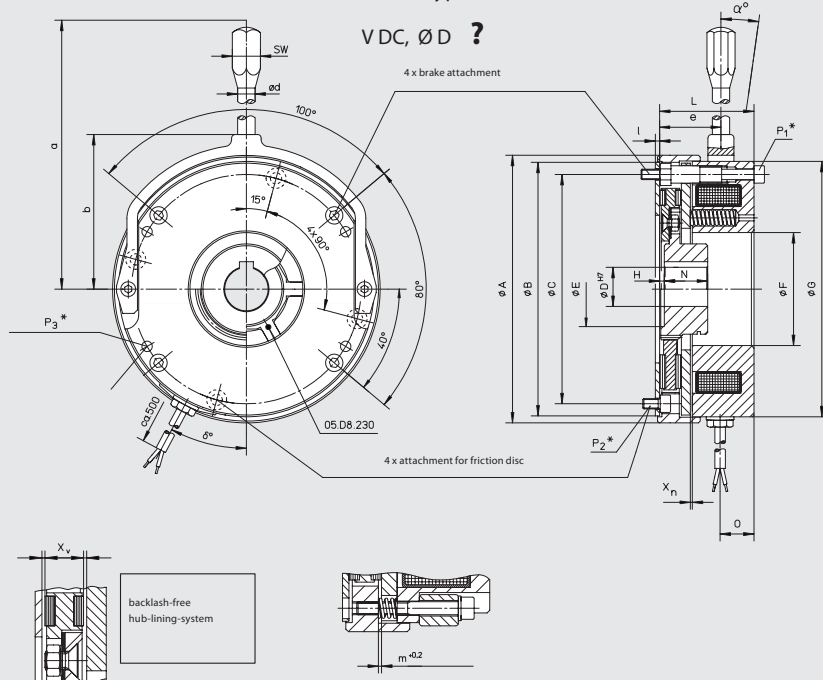

COMBISTOP L

...D8.230... with hand release

COMBISTOP L

...D8.630... with hand release with backlash-free hub-lining-system



COMBISTOP Accessories

To adapt the spring-applied brakes to the various requirements of different applications an extensive program with a wide range of accessories is available.

Please contact us to discuss your requirements. To ensure correct selection we have on hand an experienced team of application engineers to assist you in all aspects of selection, enabling you to get the optimum solution.

Accessory - dust protection ring (IP44) ...08.550-0009

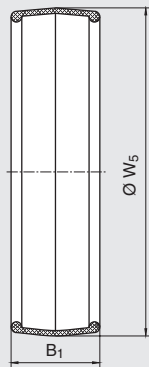

To protect the friction surfaces against dust or dripping water different sizes of dust protection rings are available. When fitting the **COMBISTOP** with a dust protection ring the friction disc must be used on the motor side. This friction disc will be supplied nitrated and is especially designed to hold the dust protection ring.

article number xx.08.550-0009										
size	02	03	04	05	06	07	08	09	10	11
B_1	22.5	25	33	33.5	38.5	45.5	49	54.5	63	upon request
W_5	86	103	129	149	167	195	222	259	310	

all dimensions in mm

Accessory - micro switch

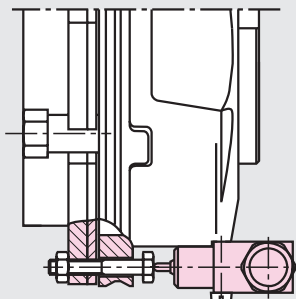

The use of **COMBISTOP** can be fitted with a micro switch for monitoring the functions and the wear. The use of **COMBISTOP** with micro switch is particularly sensible for braking motors on hoisting gears that are operated with frequency inverters.

Detailed mounting dimensions and technical data are provided in the dimension sheet 08.M01-3-0604.

Friction discs and **flanges** provide suitable counter-rotation surfaces for the spring applied brakes and are available in hardened and rustproof design.

Accessory - friction discs ...08.451...

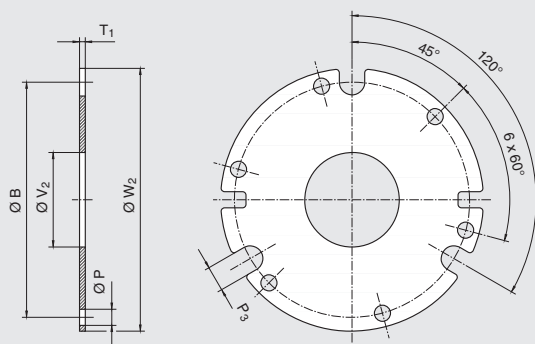

article number xx.08.451-xxxx										
size	02	03	04	05	06	07	08	09	10	11
B	72	90	112	132	145	170	196	230	278	
P	4.5	5.5	6.5	6.5	9	9	9	11	11	
T₁	1.5	2	2	2	2.5	2.5	2.5	3	4	
P₃	7.5	8.5	10.5	18	18	18	14.5	17	17	
V₂	27	35.5	42.5	47	51	85	100	105	198	
W₂	82	98	123	146	157	188	214	250	302	
weight [kg]	0.05	0.10	0.15	0.22	0.30	0.40	0.64	0.93	1.50	

all dimensions in mm

Accessory - friction discs with collar ...08.515...

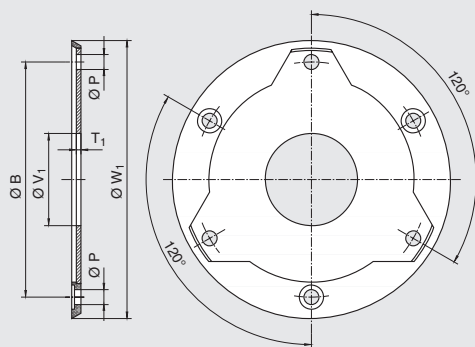

article number xx.08.515-xxxx										
size	02	03	04	05	06	07	08	09	10	11
B	72	90	112	132	145					
P	4.5	5.5	6.5	6.5	9					
T₁	1.5	2	2	2	2.5					
V₁	27	35.5	42.5	47	51					
W₁	88.5	106	132	153	171					
weight[kg]	0.05	0.10	0.15	0.25	0.35					

all dimensions in mm

Accessory - flange with collar for dust protection ring ...08.510...

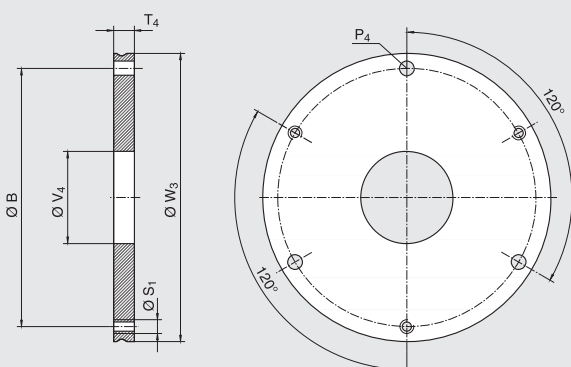

article number xx.38.510-0009											
size	00	02	03	04	05	06	07	08	09	10	11
B	52	72	90	112	132	145	170	196	230	278	325
P₄		3x4,3	3x5,3	3x6,4	3x6,4	3x9	3x9	3x9	3x11	6x11	8x11
S₁		3xM4	3xM5	3xM6	3xM6	3xM8	3xM8	3xM8	3xM10	6xM10	8xM10
T₄	5	6	7	9	9	11	11	11	11	12.5	20
V₄	26	20	30	40	45	55	65	75	90	120	160
W₃	60	83	100	125	145	163	190	217	254	306	363
weight [kg]	0.08	0.20	0.35	0.75	1	1.50	2.10	2.70	3.70	5.90	12.7

all dimensions in mm

Technical data

max. speed

size	operating stop [rpm]	max. speed		J		g_{min} min lining thickness [mm]	X_n max air gap [mm]
		type M, P, T emergency stop [rpm]	type N, H, D emergency stop [rpm]	type M, P, T [10^{-3} kgm^2]	type N, H, D [10^{-3} kgm^2]		
0B	3000	6000	-	0.001	-	-	-
02	3000	6000	6000	0.025	0.025	5.5	0.4
03	3000	6000	6000	0.072	0.072	6.5	0.5
04	3000	6000	6000	0.136	0.136	8	0.6
05	3000	5000	5000	0.35	0.35	10	0.6
06	3000	5000	5000	0.56	0.56	10	1
07	3000	4500	4500	1.57	1.57	10	1
08	3000	3500	3500	5.92	5.92	11	1.2
09	1500	3000	3000	7.38	7.38	12	1.2
10	1500	3000	3000	20.54	20.54	14	1.5
11	1500		2000		180.7	28	1.5

g_{min} min. permissible lining thickness [mm] ¹⁾ bei Bremse Typ D zur Berechnung 2 x [J] verwenden

Friction switching frequency Type M, P, T

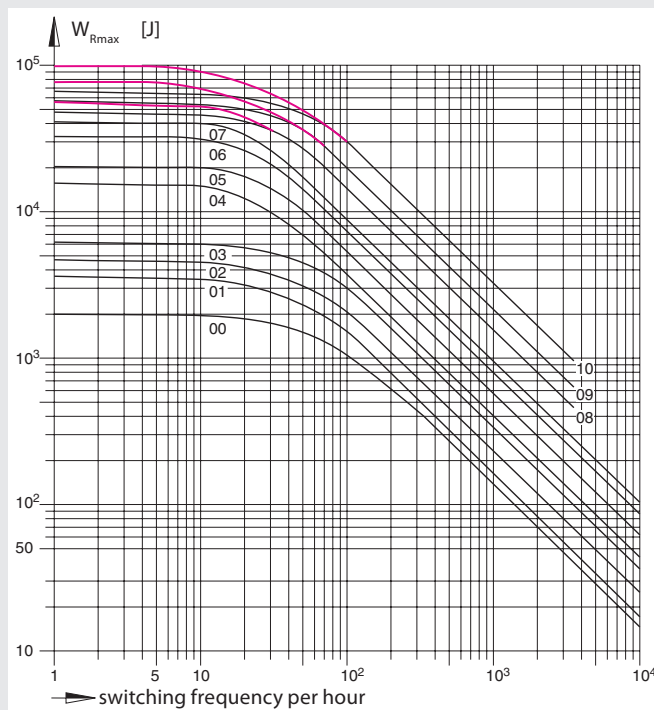

Red line for brake without friction disc

Friction switching frequency Type N, H, D

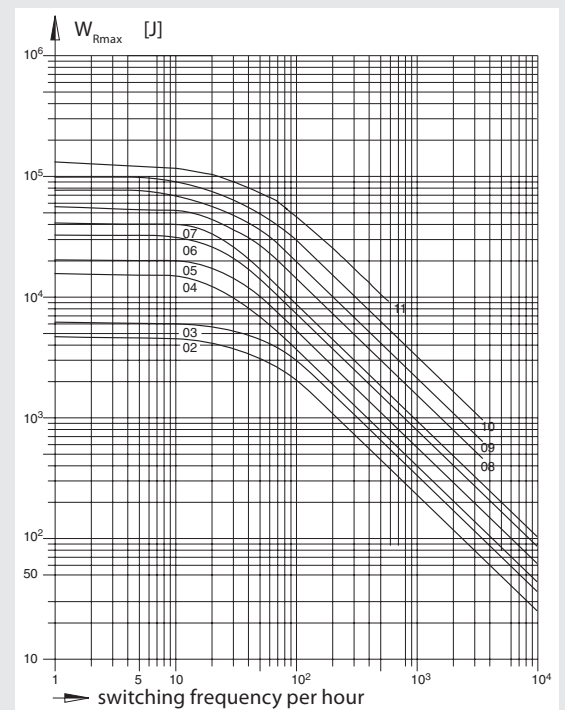

Permissible friction W_{Rmax} [J] dependence the switching frequency

Valid only for the stated revolutions per minute

type **M, P, T, N, H, D** size 0B. ... 07. - 3000 rpm

type **P, T, N, H, D** size 08. ... 11. - 1500 rpm

The values for W_{Rmax} are valid for standard brakes and a second friction surface of casting. Depending on application these values may be exceeded or remained under. Rustfree friction discs, or speeds higher than specified in the diagram, reduce the permissible friction work considerably. If the rated torque of the brake is reduced by turning the adjustment ring (optional) the permissible friction work increases.

COMBISTOP

Switching cycles and switching times

size	switching cycles				t_2				AC-switching				DC-switching			
	SC_1 [1/min]		SC_2 [1/min]		t_2 [ms]		$t_{11\sim}$ [ms]		$t_{1\sim}$ [ms]		$t_{11=}$ [ms]		$t_{1=}$ [ms]			
	M, P, T	N, H, D	M, P, T	N, H, D	M, P, T	N, H, D	M, P, T	N, H, D	M, P, T	N, H, D	M, P, T	N, H, D	M, P, T	N, H, D		
00	70		140		35		60		100		12		25			
02	60	60	120	120	40	40	40	70	90	100	10	10	20	20		
03	40	60	75	75	60	55	80	100	140	150	15	15	30	30		
04	40	60	75	75	100	90	140	180	200	200	20	25	50	50		
05	25	25	50	50	120	110	180	220	240	240	25	25	55	55		
06	5	5	10	10	240	240	200	260	330	330	25	25	90	90		
07	5	5	10	10	240	220	400	400	650	650	50	40	150	120		
08	5	5	10	10	300	320	700	700	900	900	60	50	180	180		
09	2	2	5	5	350	350	900	900	1200	1200	60	60	220	220		
10	1	2	3	3	350	400	1400	1400	1800	2000	60	100	250	300		
11		1		2		750		3100		3500		450		1000		

COMBISTOP Typs: M, P, T, **N, H, D** (see page 4)

SC_1 applicable for rectifiers:

02.91.010-CE07

02.91.020-CE07

02.91.010-CEM9

SC_2 applicable for rectifiers:

04.91.010-CE07

04.91.020-CE07

05.91.010-CE09

06.91.010-CE09

SC maximal permissible switching cycle

at DC-side switching, 100% on time and max. operating temperature of 80 °C.

[min⁻¹]

t₁ engaging time

time from disconnecting the current to attaining the rated torque.

[ms]

t₁₁ engagement delay time

time from disconnecting the current to the rise of the torque.

[ms]

t₂ release time

time from connecting the current to the beginning of torque decrease.

[ms]

The designation of the switching times corresponds to DIN VDE 580.

Switching cycles COMBISTOP with POWERBOX

size	t_2 [ms]	max. air gap [mm]	switching cycles [1/min]
02	20	1.0	55
03	35	1.8	40
04	50	2.1	40
05	60	3.0	25
06	120	3.0	5
07	120	3.5	5
08	150	3.0	5
09	170	3.5	2
10*	180	4.5	1

* Continuous operation only permissible at 45°C!

230 V AC input voltage and 105 V DC coil

Switching times apply to rated air gap X

Switching cycles apply to DC-side switching

Power supply

COMBISTOP requires DC voltage for operation. For the power supply different half-wave or full-wave rectifiers of the series **COMBITRON 98** are available for DC or AC-side switching, which, depending on the type, are suitable for connection voltages up to 720 V AC rated voltage.

The switching characteristics and functions of the **COMBISTOP** can be optimized through the rapid switch rectifier **COMBITRON 98**.

COMBIPERM are electromagnetically released permanent magnet brakes and clutches for dry operation whose flux is generated by permanent magnets. This effect permits the connection of shafts in voltage free condition or the safe deceleration of masses.

You find possible shaft diameters in the "Bore Table" on page 51.

On request we adapt **COMBIPERM** to your constructional and electrical requirements.

Program Schedule

COMBIPERM quiescent-current operated brakes and clutches

Holding brake with Emergency-Stop-function **0.4 ... 145 Nm** page 17 **COMBIPERM P1**

Clutch quiescent-current operated **6 ... 120 Nm** page 19 **COMBIPERM 22**

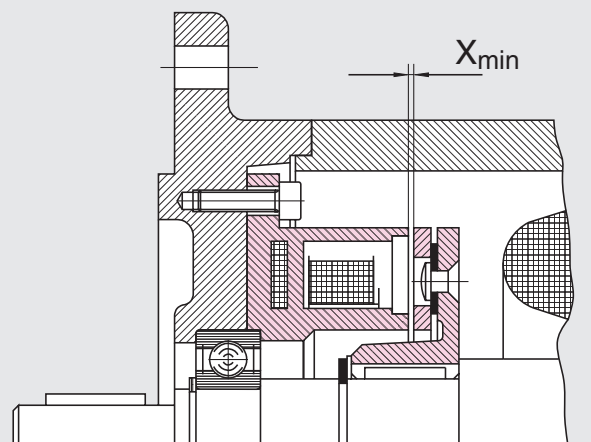

COMBIPERM P1

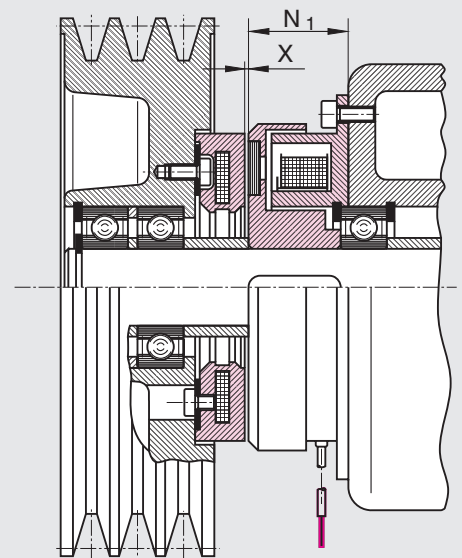

COMBIPERM 22

Technical data

moments of inertia, friction, -rating page 20

switching times page 20

dimensioning / calculation page 50

bore table COMBINORM / COMBIPERM page 51

COMBIPERM P1 first choice for your servomotor

are powerful permanent magnet brakes with frictionally engaged, backlash-free effect. Rare earth magnets create a force field, which is cancelled by the counter-pole magnet coil (opened) in current-supplied condition and in combination with the membrane spring on the armature it ensures a residual torque-free separation independent of the installation position.

COMBIPERM P1 are designed for rated operating voltage 24 V DC according to ISO class F (max. 155°C) and ensure a safe operation within a wide range of temperatures. On request versions in ISO class H (180°C) and other operating voltages are available.

Range of application: e.g. machine building, medical technology, industrial robots, servo-drives

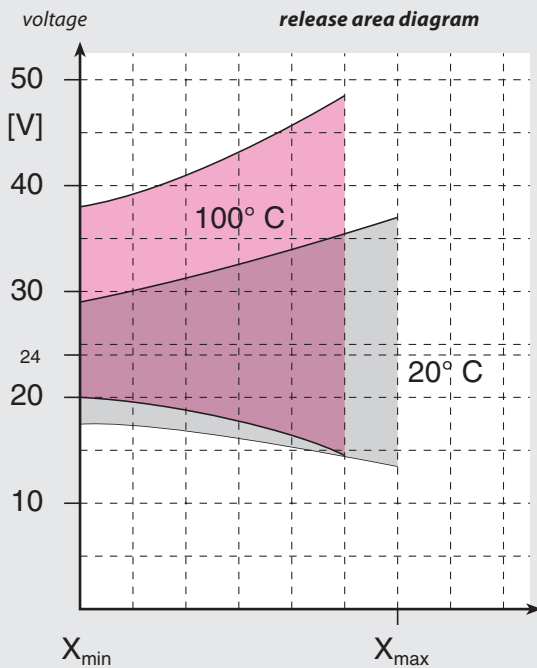
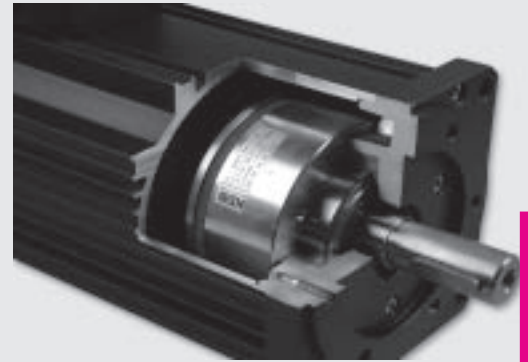

Please bear in mind

- that magnetic materials within the direct surroundings can weaken the torque, reduce maximal air gaps and lead to a shifting of the release range.
- that the rated torques are achieved after a required running-in process (please see instruction manual).
- that the torques become less at higher speeds.

ordering example: **COMBIPERM P1**

size 06. P1. 130 design
type

V DC, Ø d₃₀ ?

ordering example: **COMBIPERM 22**

size 06. 22. 130 design
type

V DC, Ø d, Ø d₁ ?

COMBIPERM
- brake with current -

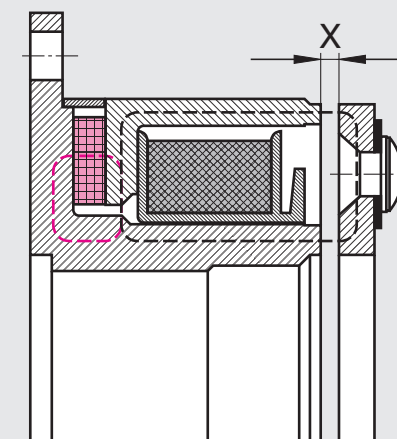

COMBIPERM
- brake without current -

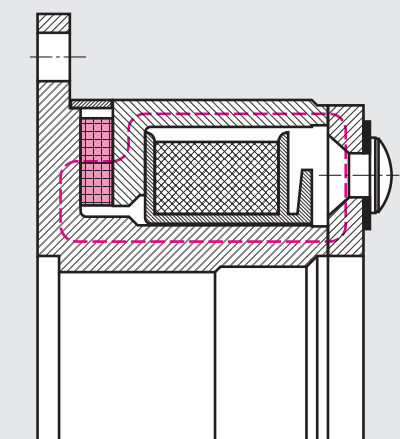

COMBIPERM

COMBIPERM P1

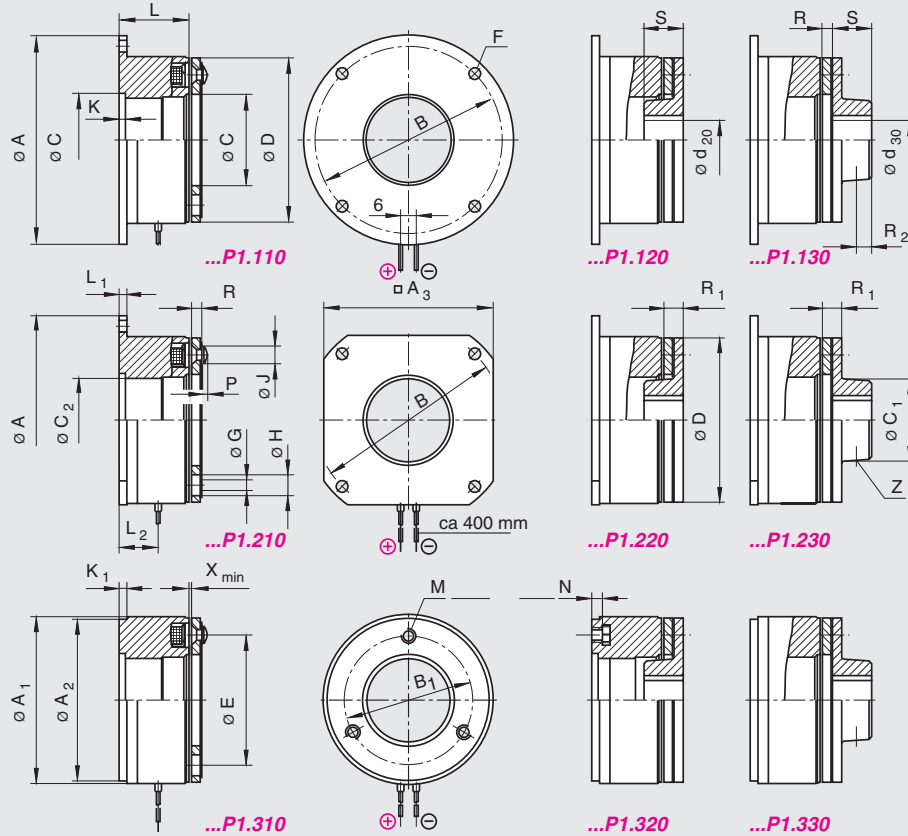

size	M _{2N} ¹⁾ [Nm]	P ₂₀ [W]	A _{h8}	A ₁	A _{2 h8}	A ₃	B	B ₁	C ^{H8}	C ₁	C ₂	D	E	ØF	G	H	J	K
01	0.4	8	39	28	28	32	33.5	22	11	13.5	-	28	19.5	3.4	2x2.1	5.3	4.5	-
02	1	10	45	32.2	32	34	38	23	12.5	16	-	32	23	3.4	3x2.6	6	5	-
03	2	11	54	41	40	42	47	28.5	19	22	-	40	30	3.4	3x3.1	6	5.5	-
05	4.5	12	65	51.5	50	53	58	40	26	24	24	50	38	3.4	3x3.1	6.5	5.5	2
06	9	18	80	64	63	66	72	49	35	32	32	63	50	4.5	3x4.1	10	8	2
07	18	24	100	80.8	80	83	90	63	42	38	38	80	60	5.5	3x4.1	11	8	2
08	36	26	125	101	100	103	112	78	52	48	48.5	100	76	6.5	3x5.1	11.5	10	2.5
09	72	40	150	126	125	128	137	106	62	57	58	125	95	6.5	3x6.1	15	11.5	3.5
10	145	50	190	161	160	163	175	135	80	71	75	160	120	9	3x8.1	21	14.5	3.5

size	K ₁	L	L ₁	L ₂	M	N	P	R	R ₁	R ₂	S	d ₂₀ ^{H7}	d ₃₀ ^{H7}	d ₃₀ ^{H7}	X _{min}	X _{max} ^{20°}	Z	weight kg	
01	3	19.5	2	10.5	2xM3	3	1	2.25	4.25	2.7	7	6	6	upon request*	8	0.15	0.3	1xM3	0.1
02	2	21.5	2	10.5	3xM3	3	1.3	2.1	4.1	4	10	8	8		10	0.15	0.3	1xM3	0.1
03	2	22.5	2	12	3xM3	3	1.5	2.6	5.2	5	12	10	12		15	0.15	0.4	1xM4	0.2
05	2	28.5	2	14	3xM3	3	1.5	3	6	5	12	15	15		19	0.2	0.5	1xM5	0.35
06	3	26.8	3	15	3xM4	4	2	3.9	7.4	6	15	18	18		25	0.3	0.65	1xM6	0.55
07	3	29.9	3	16.5	3xM4	5	2	4.5	8.5	8	20	22	22		30	0.3	0.8	1xM6	0.85
08	4	33.9	4	19.5	3xM5	6.2	2.5	6.2	11.2	10	25	30	30		38	0.35	0.9	1xM8	1.6
09	5	37.8	5	23	3xM6	7	3	7.3	13.3	12	30	40	40		50	0.4	1.0	2xM10	2.9
10	6	42.6	6	24	3xM8	9.5	4	9.4	16.4	15	38	50	50		65	0.5	1.2	2xM10	5.4

¹⁾ rated torque after running in process all dimensions in mm keyway to DIN 6885/1-P9 standard voltage 24 V DC (release range + 6 % / - 10 %) according to VDE 0580, isolation class F* hub DIN 6885/1

COMBIPERM 22

COMBIPERM 22 are permanent magnet **clutches**, which transmit in currentless condition frictionally engaged torque. The magnetic circle is optimized by the arrangement of the permanent magnets in the armature, thus permitting the transmission of high torques on small constructional spaces. The opening of the friction-type connection takes place by the antipole connection of the electromagnetic circuit, thereby neutralizing the force action of the permanent magnets

Range of application: e.g. robot technique, medical equipment

Size	M _{2N} ¹⁾ [Nm]	P ₂₀ [W]	a ₁	A h8	A ₁	b ₁	B	B ₁	B ₃	Ø C ₃	C ₁	C ₇ k6	C H8	C ₂	d max	d ₁ max	d ₃ max	d ₆	D	D ₂	E
06	6	15	10	80	-	40.3	72	-	-	32	32	38	35	36.0	18	20	17	12	63	-	50
07	12	20	14	100	-	47.0	90	-	37	39	38	45	42	43.5	22	25	22	15	80	-	60
08	24	28	16	125	62.5	57.3	112	56.0	47	48	48	55	52	53.8	30	30	30	20	100	85	76
09	50	35	18	150	75.0	66.2	137	68.5	52	62	58	64	62	63.8	35	35	35	25	125	95	95
10	120	50	20	190	95.0	77.6	175	87.5	62	80	73	75	80	82.1	45	50	50	30	160	126	120

Size	E ₁	ØF	ØF ₁	ØG	ØH ₂	J ₂	K	K ₁	K ₅	N ₁	O	O ₁	O ₂	M ₂	M ₃	L ₆	P ₁	P ₂	P ₃	P ₄	P ₅
06	-	4x4.5	-	3x4.1	3x8	3x7.0	3.5	1.6	12.2	24.0	6	3	19.0	27.5	36	20	3.3	3.9	-	-	4.0
07	-	4x5.5	-	3x4.1	3x8	3x7.0	4.25	1.85	13.5	26.5	7	3	21.5	34	43	25	3.3	3.9	-	-	4.5
08	45.75	4x6.6	6.5	3x5.1	3x10	3x8.5	5.0	2.15	16.0	30.0	8	4	24.0	42	52	30	4.0	4.7	16.2	12	5.5
09	55.0	4x6.6	6.5	3x6.1	3x11	3x10.0	5.5	2.15	20.0	33.5	9	4	25.0	50	66	40	4.7	5.2	18.7	14	5.5
10	72.5	4x9.0	9.0	3x8.1	3x15	3x13.0	6.0	2.65	22.7	37.5	11	5	31.5	61	80	50	5.8	6.5	21.5	14	7.0

Size	R ₅	R ₆	R ₇	V ₁	S	S ₁	S ₃	S ₇	T	V	W	W ₁	X	Z ₁	Z ₂	Weight [kg]					
																110	130/140	210(710)	230(730)	240(740)	
06	12.5	16	16.0	6	15	22	41.0	18.6	67	-	-	-	0.3	1xM6	-	110	0.5	0.5	1.0	1.0	1.0
07	14.0	18	17.7	8	20	24	45.0	24.2	85	-	-	-	0.3	1xM6	3xM4	1.0	1.25	1.25	1.75	1.75	1.75
08	17.0	22	21.6	10	25	27	51.5	30.7	106	M5	M4	46.5	0.35	1xM8	4xM4	2.0	2.25	2.25	3.0	3.0	3.0
09	20.0	26	25.5	12	30	30	55.0	40.8	133	M8	M5	55.0	0.4	2xM10	4xM4	3.5	4.0	4.0	5.0	5.0	5.0
10	23.0	30	29.5	15	38	34	65.0	52.5	169	M8	M5	72.5	0.5	2xM10	4xM5	11.5	12.5	12.5	10.0	10.0	10.0

¹⁾ rated torque after running in process all dimensions in mm keyway to DIN 6885/1⁹⁾ standard voltage 24 V DC (release range +6 %/-10 %) according to VDE 0580, isolation class „B“ hub DIN 6885/1

shaft mounted clutch

COMBIPERM 22

...22.XX0-...

size 08 + 12

size 06 + 07

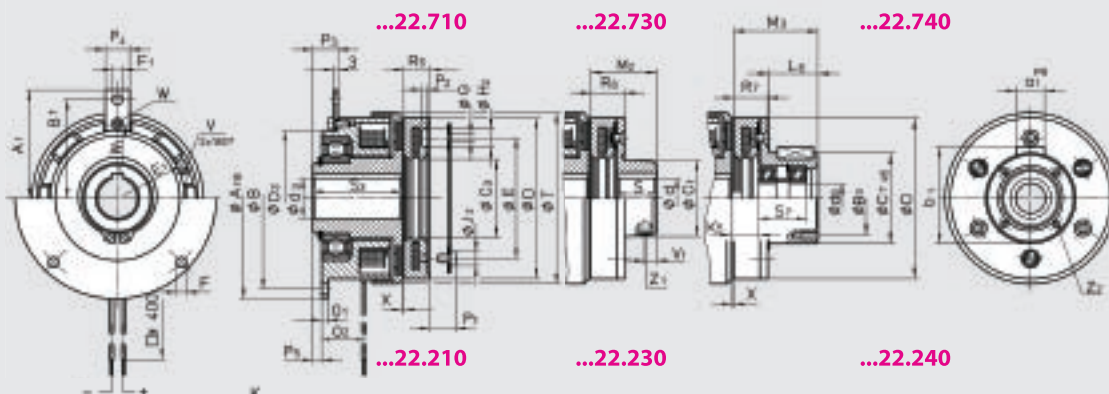

flange mounted clutch

COMBIPERM 22

...22.XX0-...

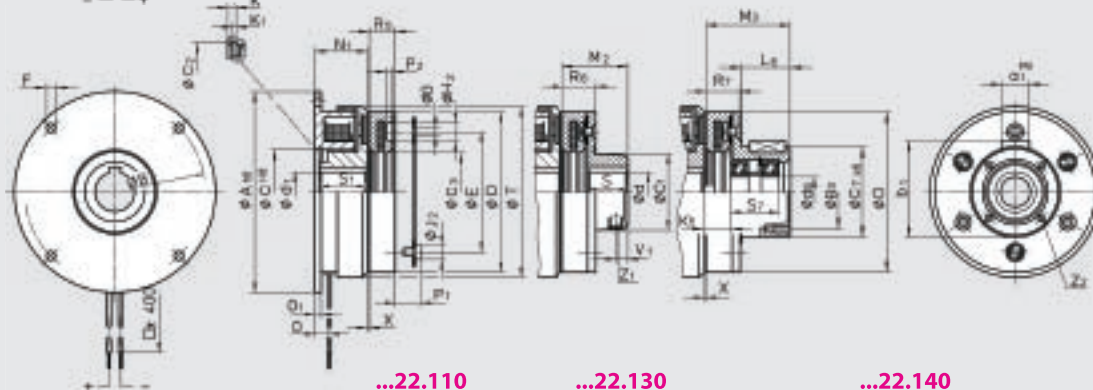

Technical data

COMBIPERM P1 / 22			01	02	03	05	06	07	08	
size										
M_{2N}¹⁾	P1	20°	0.4	1	2	4.5	9	18	36	
	22	20°	[Nm]				6	12	24	
M_{stat}	P1	100°	0.35	0.8	1.8	4	8	15	32	
			[Nm]	0.3	0.8	1.7	3.8	7.5	15	
M_{dyn}	P1	20°	0.001	0.001	0.001	0.001	0.002	0.004	0.012	
			[kgm ²]	3000	3000	3000	3000	2000	2000	
P₂₀	P1		8	10	11	12	18	24	26	
	22		[W]				15	20	28	
J										
armature	P1.110		0.01	0.014	0.045	0.122	0.37	1.15	4	
	P1.120/130		0.013	0.021	0.068	0.18	0.54	1.66	5.56	
	22.110/210/710					1.18	3.7	10.9	31.7	
	22.130/230/730		[10 ⁻⁴ kgm ²]			1.38	4.23	12.85	36.6	
rotor	22.140/240/740					1.86	5.6	16.4	46.6	
	22.110/130/140					0.825	2.38	7.25	21.9	
	22.210/230/240/710/730/740					0.9	2.6	8	24	
W_{R0,1}	P1		200	300	410	580	890	1290	2900	
			[kJ]							
			[kgm ²]	0.001	0.001	0.001	0.001	0.0015	0.004	0.0120
W_{R0,1}	P1		3000	3000	3000	3000	2000	2000	2000	
			[rpm]							
	22		[10 ⁷ J]				0.67	1.14	1.77	
X_{max}	P1	20°	0.3	0.3	0.4	0.5	0.65	0.8	0.9	
	22		[mm]				0.4	0.4	0.5	
X_{min}	P1		0.15	0.15	0.15	0.2	0.3	0.3	0.35	
	22						0.3	0.3	0.35	
n_{max}	P1		10000	10000	10000	10000	10000	10000	10000	
	22		[rpm]				8000	6000	5000	
switching times	P1	t ₂	[ms]	10	12	25	35	40	50	90
		t ₁₁ =		2	2	2	2	2	3	3
		t ₁ =		6	6	6	7	7	10	22
	22	t ₂						35	40	70
		t ₁₁ =						6	7	8
		t ₁ =						30	35	42

Legend

M_{2N}¹⁾ rated torque after running in process (slip speed 20 rpm)

[Nm] t₁

Engaging time: Time from disconnecting the current until the rated torque is attained. [ms]

M_{stat} 100°C rated torque at 100°C (slip speed 20 rpm)

[Nm] t₁₁

Engaging delay time: Time from disconnecting the current until the torque rises. [ms]

M_{dyn} 20°C switching torque at specified conditions

[Nm] t₂

Release time: Time from connecting the current until the torque decreases. [ms]

P₂₀ power at 20°C

[W]

J moment of inertia

[kgm²]

n_{max} max. speed

[rpm]

The stated switching times are achieved with adjusted nominal air-gap (x_{min}).

X_{min} nominal air gap

[mm]

These are averages whose dispersion depends on the power supply and coil temperature.

X_{max} max. air gap at which the armature attracts

[mm]

W_{R0,1} friction work up to 0.1 mm abrasion

[kJ]

COMBIPERM

09	10
72	145
50	120
62	130
55	110
0.036	0.1
2000	2000
40	50
35	50
11.5	39
16	53
95	
110	
140	
67.4	
73	
6200	13000
0.036	0.1
2000	2000
2.86	4.66
1	1.2
0.6	0.7
0.4	0.5
0.4	0.5
8000	8000
4000	3000
140	190
7	12
25	65
90	105
10	12
50	60

Permissible friction W_{Rmax} [J]
depending on the switching frequency type P1

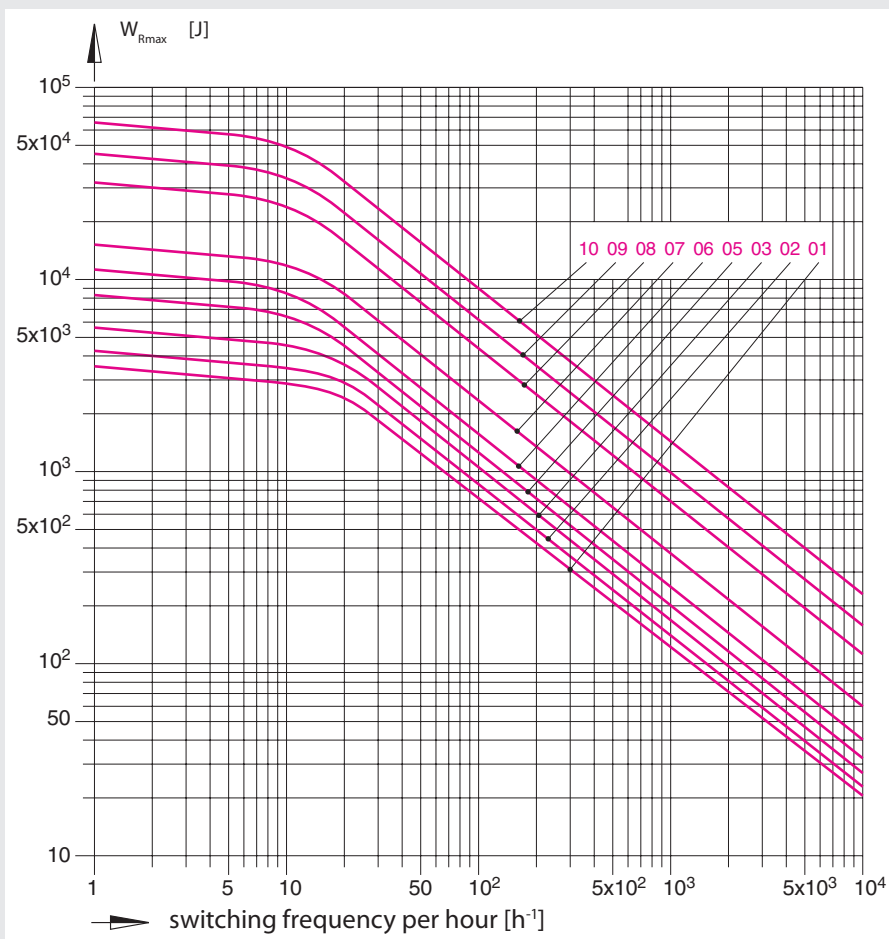

The values for W_{Rmax} apply to a speed 3000 rpm. Dependent on the actual application W_{Rmax} may exceed or fall below these values.

Power Supply

COMBIPERM needs a smoothed DC voltage. To ensure a safe operation in case of large temperature variations, the coil should be supplied with constant current.

Please pay attention to the polarity of the connection leads.
(positive = green/red, negative = green/blue).

KEB supplies transformer rectifiers with capacitor for the 24 V DC power supply.
Please refer to our dimension diagram for mounting dimensions and technical datas
92.M01-4-0702.

COMBINORM - operating-current operated brakes and clutches use the flux of an electromagnet, concentrated on two pole surfaces, for the connecting, separating or holding of shafts and the connected loads.

COMBINORM covers a complete program with brakes, clutches and combinations as installation and attachment components for the applications in machines, plants and equipment in the application range of 0.5 to 500 Nm. On request we adapt the **COMBINORM** to your constructional and electrical requirements.

Program Schedule

COMBINORM Operating-current operated brakes and clutches

Operating current brake 0.5 ... 500 Nm	page 24	COMBINORM B
Operating current clutch-brake-combination 7 ... 500 Nm	page 26	COMBINORM K
Operating current clutch 0.5 ... 500 Nm	page 26	COMBINORM C
Operating current toothed clutch 21 ... 390 Nm	page 32	COMBINORM T

Technical data

Moments of inertia, friction, rating.....page 34

Switching times page 34

Dimensioning / calculations page 50

bores table COMBINORM / COMBIPERM.....page 51

ordering example: **COMBINORM C**

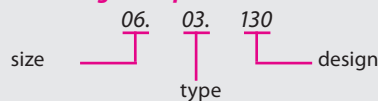

V DC, Ø d, Ø d ?

COMBINORM

Installation Examples

flange mounted brakes

COMBINORM B ...02.120...

- ① brake magnet
- ② armature
- ⑤ hub
- ⑥ spring

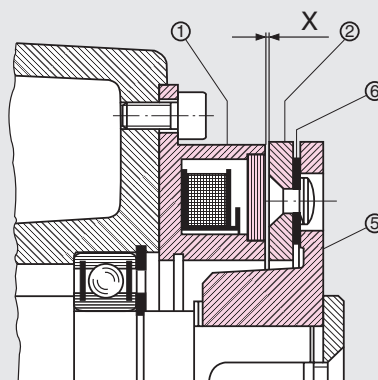

flange mounted clutches

COMBINORM C and T ...03.110...

- ② armature
- ③ clutch magnet
- ④ rotor
- ⑥ spring

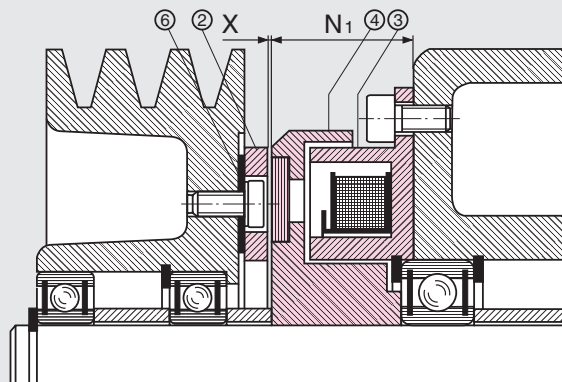

shaft mounted clutches

COMBINORM C and T ...03.810...

- ② armature
- ③ clutch magnet
- ④ rotor
- ⑥ spring

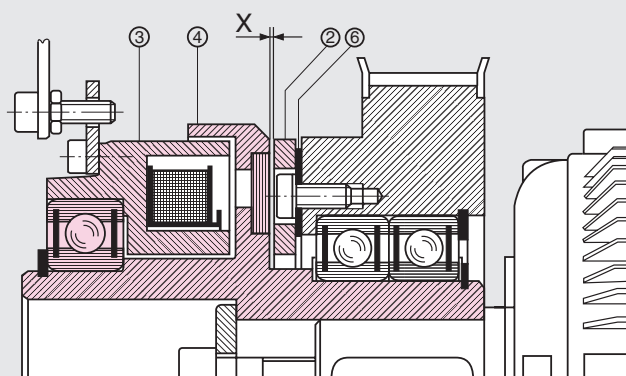

clutch-brake-combination

COMBINORM K ...04.170...

- ① brake magnet
- ② armature
- ③ clutch magnet
- ④ rotor
- ⑤ hub
- ⑥ spring

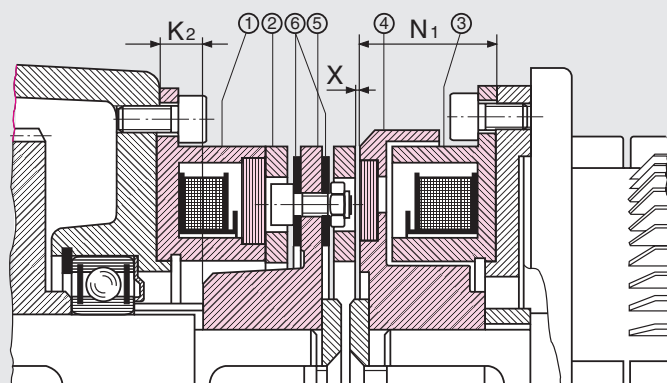

COMBINORM

COMBINORM B

are the most economical solution for the deceleration and holding of loads for the flange- and shaft-mounted installation in machines and plants.

The magnets with a rated voltage of 24 V DC are designed according to ISO class B and are available in various special voltages on request.

Shaft mounted brakes

COMBINORM B

...02.320...

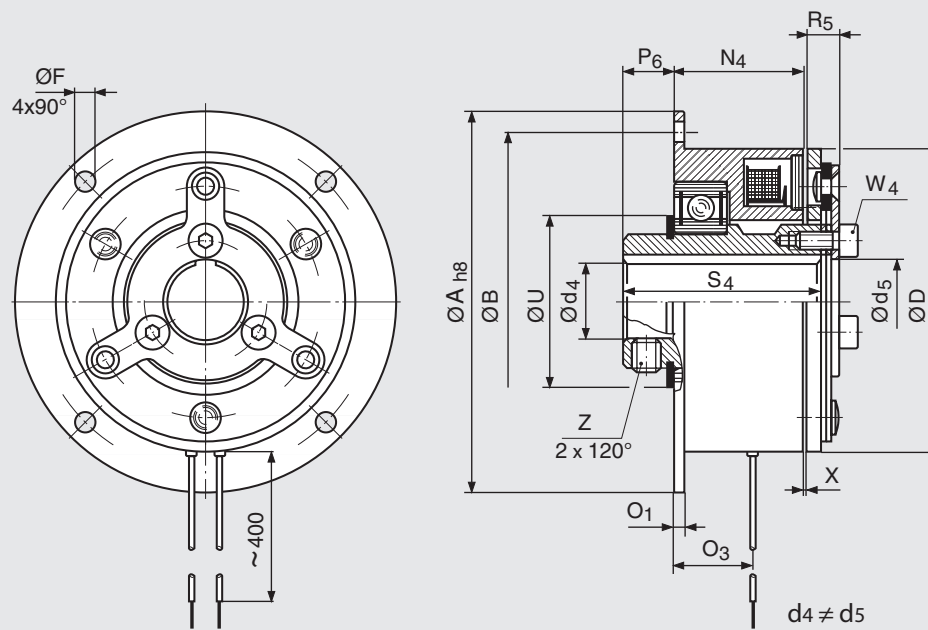

available shaft diameters page 51

...02.320

size	$M_{2N}^{(1)}$ [Nm]	P_{20} [W]	A_{hb}	B	C^{HB}	C_1	C_2	d/d_4 max	d_5	D	E	F	G	H	J	K	K_1	M
01	0.5	6	39	33.5	11	13.5	-	6		28	19.5	3.4	2 x 2.1	5.3	4.5	-	-	9.3
02	0.75	6	45	38	13	16	13.6	8		32	23	3.4	3 x 2.6	6	5	3	1.1	12.1
03	1.5	8	54	47	19	22	20	10		40	30	3.4	3 x 3.1	6	5.5	3	1.1	14.7
05	3	10	65	58	26	24	27	15		50	38	3.4	3 x 3.1	6.5	5.5	3.2	1.3	15
06	7	12	80	72	35	32	36	20	18	63	50	4.5	3 x 4.1	10	8	3.5	1.6	18.8
07	15	16	100	90	42	38	43.5	22	21	80	60	5.5	3 x 4.1	11	8	4.25	1.85	24.3
08	30	21	125	112	52	48	53.8	30	28	100	76	6.6	3 x 5.1	11.5	10	5	2.15	31
09	65	28	150	137	62	58	63.8	35	35	125	95	6.6	3 x 6.1	15	11.5	5.5	2.15	36.9
10	130	38	190	175	80	73	82.1	45	44	160	120	9	3 x 8.1	21	14.5	6	2.65	46.9
11	250	50	230	215	100	92	102.1	60		200	158	9	3 x 10.1	25	17.5	7	3.15	59.2
12	500	65	290	270	125	112	127.4	70		250	210	11	4 x 12.1	28	20.5	8	4.15	68
13	Dimensions and technical data see drawing 02.004-4-01001																	

¹⁾ rated torque after running in process All dimensions in mm keyway according to DIN 6885/1-P9 Standard voltage 24 V DC VDE 0580, ISO-class „B“

Range of application:

e.g. mail processing, winding equipment, door and gate systems, roller conveyor, strapping machines, balancing machines, sorting machines.



Flange mounted brakes

COMBINORM B

...02.1X0...

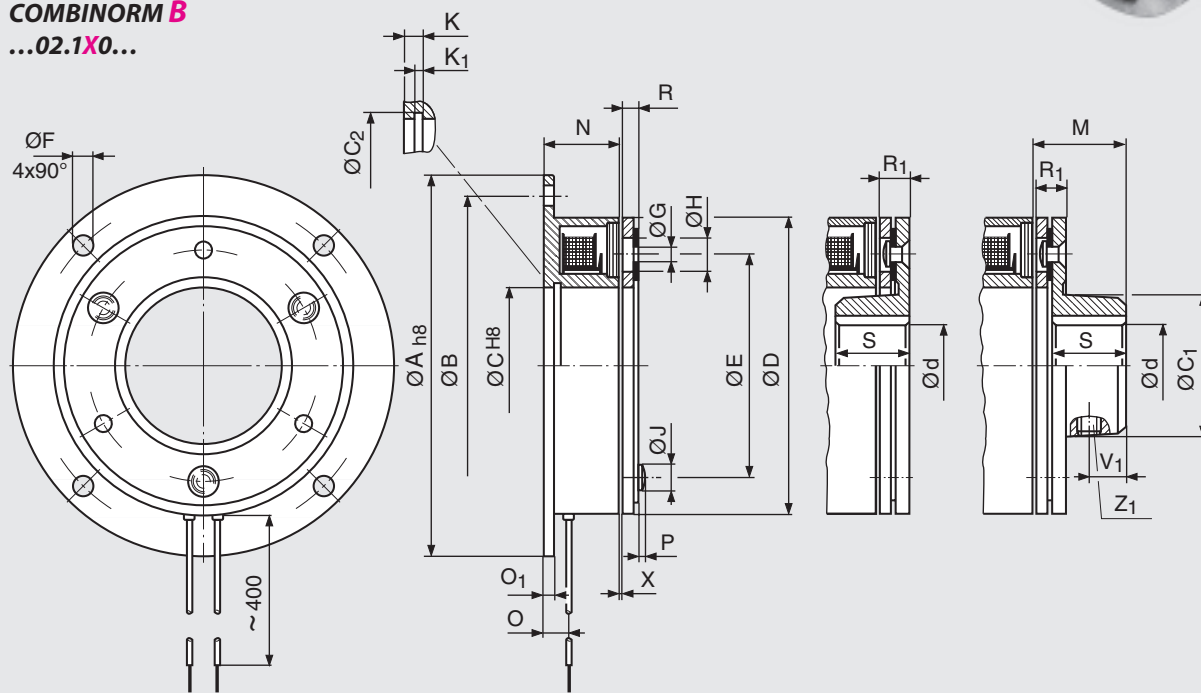

...02.110

...02.120

...02.130

N	N ₄	O	O ₁	O ₃	P	P ₆	R	R ₁	R ₅	S	S ₄	U	V ₁	W ₄	X	Z ₁	weight [kg]		
																	110	120/130	320
13.7		5	1.5		1		2.3	4.3		7			2.5		0.1	1 x M 3	0.05	0.05	
17		7.5	2		1.3		2.1	4.1		10			4		0.15	1 x M 3	0.1	0.1	
20		7	2		1.5		2.7	5.3		12			5		0.15	1 x M 4	0.15	0.15	
22		7.5	2		1.5		3	6		12			5		0.2	1 x M 5	0.2	0.25	
18	31.2	6	3	19	2	9.3	3.8	7.3	6.3	15	45	39	6	M4	0.2	1 x M 6	0.3	0.3	0.8
20	34.2	7	3	21.5	2	13.2	4.3	8.3	6.9	20	52.5	45	8	M5	0.2	1 x M 6	0.5	0.6	1.5
22	38	8	4	24	2.5	13.5	6	11	9.3	25	58.5	56	10	M6	0.2	1 x M 8	0.9	1.1	2.7
24	40	9	4	25	3	13.8	6.9	12.9	10.9	30	62	61	12	M8	0.3	2 x M10	1.7	2	4.2
26	46.3	11	5	31.5	4	17.3	8.9	15.9	14.1	38	74	84	15	M10	0.3	2 x M10	3.2	4	7.8
30		12	5		4.5		11.2	20.2		48			19		0.4	2 x M12	5.9	7	
35		15	6		5		13	24		55			22		0.4	2 x M12	11.2	13.5	

COMBINORM

COMBINORM K

covers a series of houseless construction units, designed for the connection and holding of auxiliary drives, allowing a backlash-free transmission with spring-controlled armature systems. The installation is done directly in the machine construction.

Range of application: e.g. paper processing, laundry folding equipment, feeder

available shaft diameters page 51

size	M _{2N} ¹⁾ [Nm]	P ₂₀ [W]		A _{h8}	B	C ^{H8}	C ₂ max.	d max.	d ₁	F	K	K ₁	K ₂	L ₅	N	N ₁	O	O ₁	R ₂	S	S ₆	X	weight
		K	B																				
06	7	15	12	80	72	35	36	20	20	4.5	3.5	1.6	11.2	55.1	18	24	6	3	12.9	15	20	0.2	0.85
07	15	20	16	100	90	42	43.5	22	25	5.5	4.25	1.85	9.3	61.3	20	26.5	7	3	14.6	20	22	0.2	1.5
08	30	28	21	125	112	52	53.8	30	30	6.6	5	2.15	8.9	71	22	30	8	4	18.8	25	24.5	0.2	2.7
09	65	35	28	150	137	62	63.8	35	35	6.6	5.5	2.15	7.9	79.6	24	33.5	9	4	21.8	30	27.5	0.3	4.8
10	130	50	38	190	175	80	82.1	45	50	9	6	2.65	5	90.8	26	37.5	11	5	27	38	31	0.3	9.5
11	250	68	50	230	215	100	102.1	60	65	9	7	3.15	3.4	108.2	30	44	12	5	33.8	48	37	0.4	17.9
12	500	85	65	290	270	125	127.4	70	80	11	8	4.15	5.1	125.6	35	51	15	6	39.2	55	43.5	0.4	31.5

All dimensions in mm keyway according to DIN 6885/1-P9 Standard voltage 24 V DC VDE 0580, ISO-class „B“ ¹⁾ rated torque after running in process

the switchable shaft connections are proven millions of times in the machine building and allow the controlled connection and disconnection of functional parts in an especially easy manner.

Electromagnets according to ISO class B with rated voltage of 24 V DC create a flux, whose effect leads over the pole surfaces of the rotors and armatures.

Available on request in various special voltages.

Range of application: e.g. paper processing, winding drives, door and gate systems, feed systems, strapping machines, sorting machines

available shaft diameters page 51

size	M _{2N} ¹⁾ [Nm]	P ₂₀ [W]	A _{h8}	B	C ^{H8}	C ₁	C ₂	d max	d ₁ max	D	E	F	G	H	J	K
01	0.5	6	39	33.5	11	13.5	-	6	6	28	19.5	3.4	2 x 2.1	5.3	4.5	-
02	0.75	6	45	38	13	16	13.6	8	8	32	23	3.4	3 x 2.6	6	5	3
03	1.5	8	54	47	19	22	20	10	10	40	30	3.4	3 x 3.1	6	5.5	3
05	3	10	65	58	26	24	27	15	15	50	38	3.4	3 x 3.1	6.5	5.5	3.2
06	7	15	80	72	35	32	36	18	20	63	50	4.5	3 x 4.1	10	8	3.5
07	15	20	100	90	42	38	43.5	22	25	80	60	5.5	3 x 4.1	11	8	4.25
08	30	28	125	112	52	48	53.8	30	30	100	76	6.6	3 x 5.1	11.5	10	5
09	65	35	150	137	62	58	63.8	35	35	125	95	6.6	3 x 6.1	15	11.5	5.5
10	130	50	190	175	80	73	82.1	45	50	160	120	9	3 x 8.1	21	14.5	6
11	250	68	230	215	100	92	102.1	60	65	200	158	9	3 x 10.1	25	17.5	7
12	500	85	290	270	125	112	127.4	70	80	250	210	11	4 x 12.1	28	20.5	8

All dimensions in mm keyway according to DIN 6885/1-P9 Standard voltage 24 V DC VDE 0580, ISO-class „B“ ¹⁾ rated torque after running in process

clutch-brake-combination

COMBINORM K

...04.170...

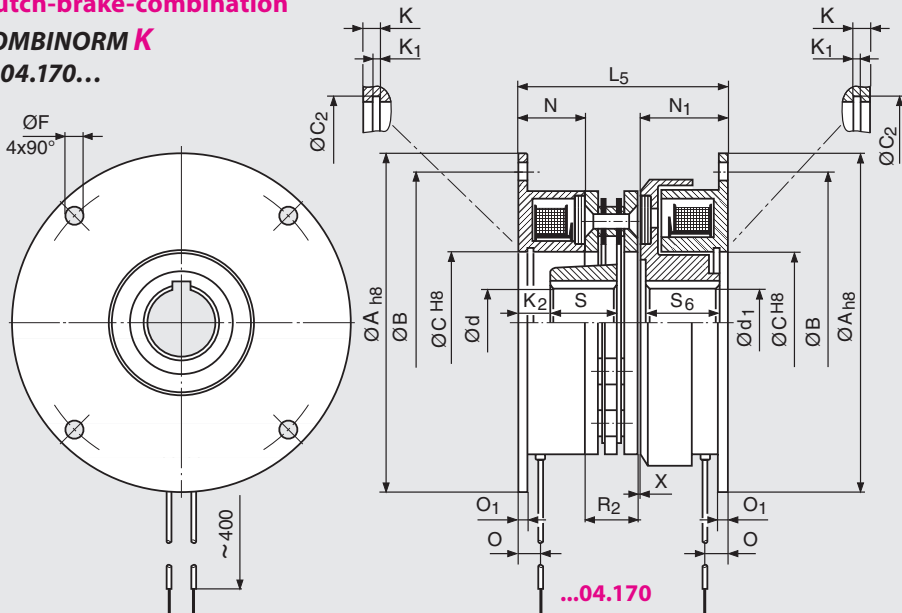

COMBINORM C

flange mounted clutches

COMBINORM C

...03.1X0...

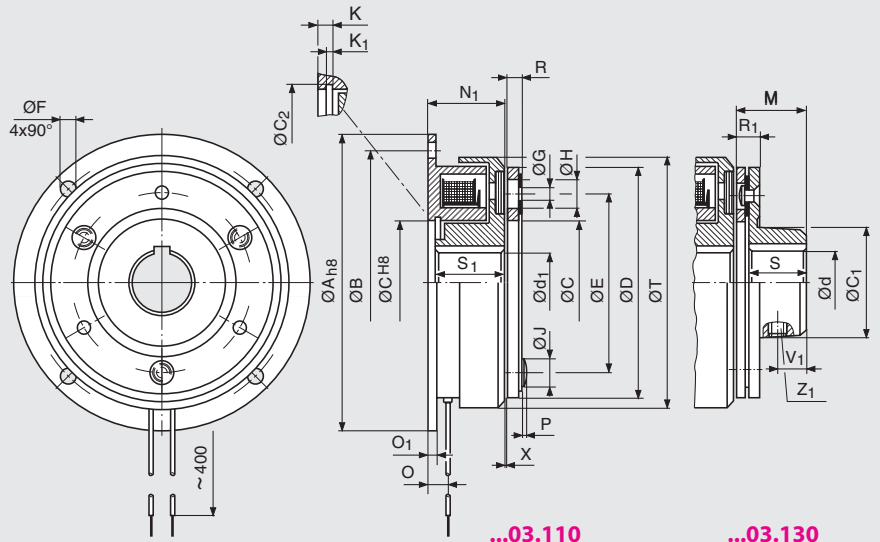

...03.110

...03.130

K ₁	M	N ₁	O	O ₁	P	R	R ₁	S	S ₁	T	V ₁	X	Z ₁	weight [kg]	
														110	130
-	9.3	18	5	1.5	1	2.3	4.3	7	16.5	31	2.5	0.1	1 x M 3	0.1	0.1
1.1	12.1	22.2	7.5	2	1.3	2.1	4.1	10	20.2	34	4	0.15	1 x M 3	0.1	0.1
1.1	14.7	25.4	7	2	1.5	2.7	5.3	12	23.4	43	5	0.15	1 x M 4	0.2	0.2
1.3	15	28.1	7.5	2	1.5	3	6	12	26.1	54	5	0.2	1 x M 5	0.35	0.4
1.6	18.8	24	6	3	2	3.8	7.3	15	22	67	6	0.2	1 x M 6	0.5	0.5
1.85	24.3	26.5	7	3	2	4.3	8.3	20	24	85	8	0.2	1 x M 6	0.9	1
2.15	31	30	8	4	2.5	6	11	25	27	106	10	0.2	1 x M 8	1.6	1.8
2.15	36.9	33.5	9	4	3	6.9	12.9	30	30	133	12	0.3	2 x M10	2.8	3.1
2.65	46.9	37.5	11	5	4	8.9	15.9	38	34	169	15	0.3	2 x M10	5.6	6.3
3.15	59.2	44	12	5	4.5	11.2	20.2	48	40	212.5	19	0.4	2 x M12	9.7	11
4.15	68	51	15	6	5	13	24	55	47	266	22	0.4	2 x M12	17.9	20.3

COMBINORM C

shaft mounted clutches size 01 ... 07

COMBINORM C
...03.6X0...

table (1)

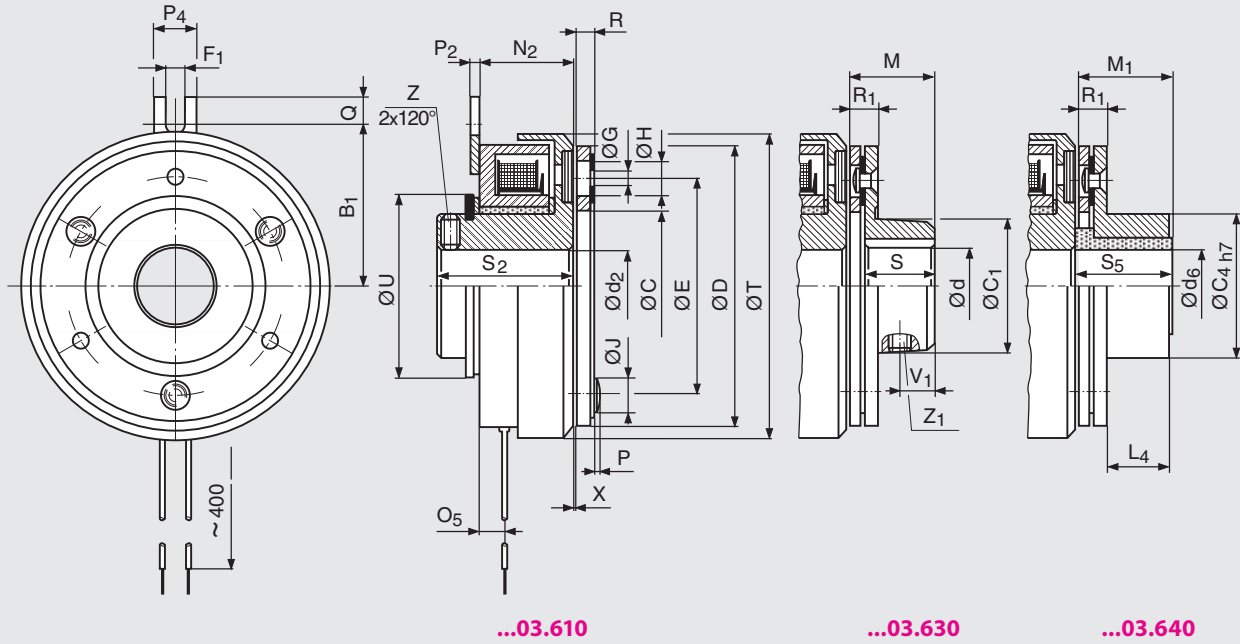

table (1)

size	$M_{2N}^{(1)}$ [Nm]	P_{20} [W]	B_1	C	C_1	C_4	d max	d_2 max	d_6 max	D	E	F_1	G	H	J	L_4	M	M_1	N_2
01	0.5	6	16.8	11	13.5	13	6	6	6	28	19.5	3.1	2 x 2.1	5.3	4.5	4.8	9.3	9.3	17.5
02	0.75	6	20	13	16	14	8	6	6	32	23	3.1	3 x 2.6	6	5	7.8	12.1	12.1	19.5
03	1.5	8	23	19	22	18	10	10	10	40	30	3.1	3 x 3.1	6	5.5	9.1	14.7	14.7	23
05	3	10	28	26	24	28	15	17	15	50	38	3.1	3 x 3.1	6.5	5.5	8.8	15	15	26
06	7	15	36	35	32	-	18	20	-	63	50	5.2	3 x 4.1	10	8	-	18.8	-	24
07	15	20	45	42	38	-	22	25	-	80	60	5.2	3 x 4.1	11	8	-	24.3	-	26

table (2)

size	$M_{2N}^{(1)}$ [Nm]	P_{20} [W]	A_{h8}	A_1	B	B_1	C	C_1	d max	d_3 max	D	D_2	E	E_1	F	F_1	G	H	J	M
06	7	15	80	-	72	-	35	32	18	17	63	-	50	-	4.5	-	3 x 4.1	10	8	18.8
07	15	20	100	-	90	-	42	38	22	22	80	-	60	-	5.5	-	3 x 4.1	11	8	24.3
08	30	28	-	62.5	-	56	52	48	30	30	100	85	76	45.75	-	6.5	3 x 5.1	11.5	10	31
09	65	35	-	75	-	68.5	62	58	35	35	125	95	95	55	-	6.5	3 x 6.1	15	11.5	36.9
10	130	50	-	95	-	87.5	80	73	45	50	160	126	120	72.5	-	9	3 x 8.1	21	14.5	46.9
11	250	68	-	115	-	107.5	100	92	60	50	200	126	158	88	-	9	3 x 10.1	19	17.5	59.1
12	500	85	-	145	-	135	125	112	70	60	250	160	210	110	-	11	4 x 12.1	28	20.5	68

All dimensions in mm keyway according to DIN 6885/1-P9 Standard voltage 24 V DC VDE 0580, ISO-class „B“ ⁽¹⁾ rated torque after running in process

available shaft diameters page 51

shaft mounted clutches size 06 ... 12

COMBINORM C
...03.XX0...

design
torque support

size 08... 12

size 06 + 07

design
flange

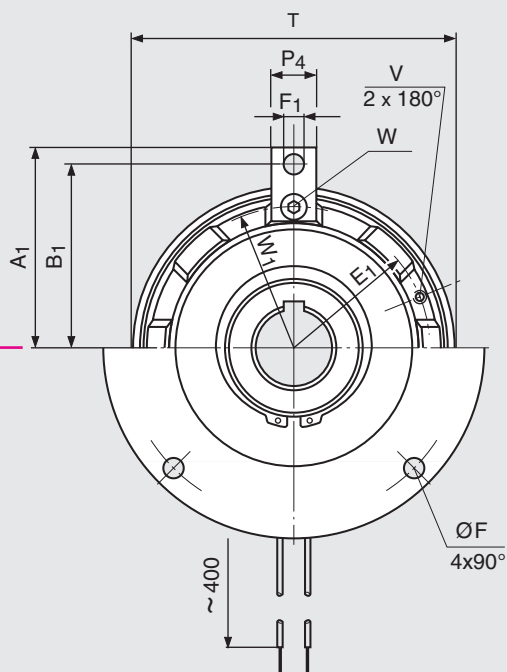

...03.730

...03.710

table (2)

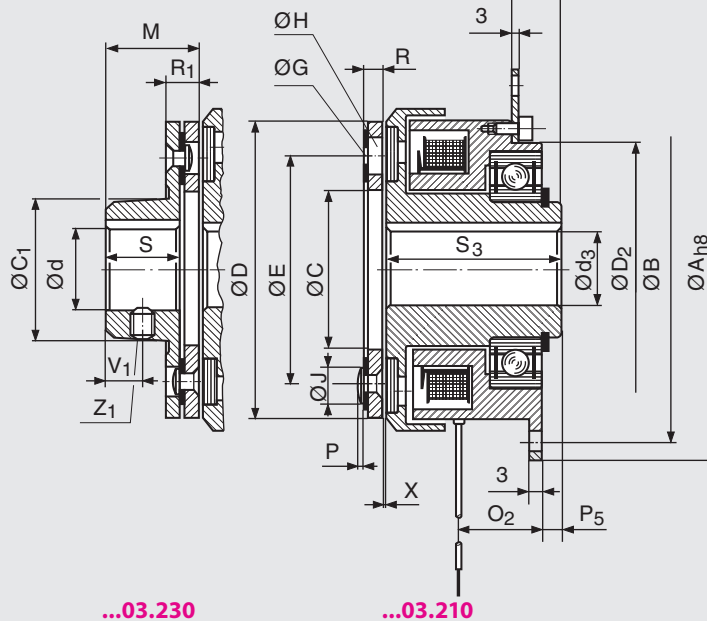

...03.230

...03.210

	O ₅	P	P ₂	P ₄	Q	R	R ₁	S	S ₂	S ₅	T	U	V ₁	X	Z	Z ₁	weight [kg]	
																	110	130
3	3.6	1	1.5	8	3	2.3	4.3	7	23.5	9.4	31	17	2,5	0.1	M3	M3	0.1	0.1
8	5	1.3	1.5	8	3	2.1	4.1	10	26.2	12.25	34	21	4	0.15	M3	M3	0.1	0.1
3	5.1	1.5	1.5	8	3	2.7	5.3	12	30.4	14.85	43	23	5	0.15	M4	M4	0.2	0.2
1	7.8	1.5	1.5	8	3	3	6	12	34.1	15.2	54	32	5	0.2	M4	M5	0.35	0.4
4	6	2	2.5	12	7	3.8	7.3	15	33	-	67	41	6	0.2	M4	M6	0.5	0.5
5	7	2	2.5	12	7	4.3	8.3	20	38	-	85	50	8	0.2	M6	M6	0.9	1

	O ₂	P	P ₃	P ₄	P ₅	R	R ₁	S	S ₃	T	V	V ₁	W	W ₁	X	Z ₁	weight [kg]	
																	210	230
3	19	2	-	-	4	3.8	7.3	15	41	67	-	6	-	-	0.2	1xM6	0.8	0.9
3	21.5	2	-	-	4.5	4.3	8.3	20	45	85	-	8	-	-	0.2	1xM6	1.5	1.6
	24	2.5	16.2	12	5.5	6	11	25	51.5	106	M5	10	M4	46.5	0.2	1xM8	2.3	2.5
9	25	3	18.7	14	5.5	6.9	12.9	30	55	133	M8	12	M5	55	0.3	2xM10	3.7	4.1
9	31.5	4	21.5	14	7	8.9	15.9	38	65	169	M8	15	M5	72.5	0.3	2xM10	7	7.7
5	32.5	4.5	23	20	7	11.15	20.15	48	71	212.5	M10	19	M6	88	0.4	2xM12	13.1	14.3
	41	5	41	22	8	13	24	55	85	266	M10	22	M8	110	0.4	2xM12	23	25

COMBINORM

COMBINORM C

shaft mounted clutches with bearing take-up for the output

COMBINORM C

...03.810...

design torque support

size 08... 12

size 06 + 07

design flange

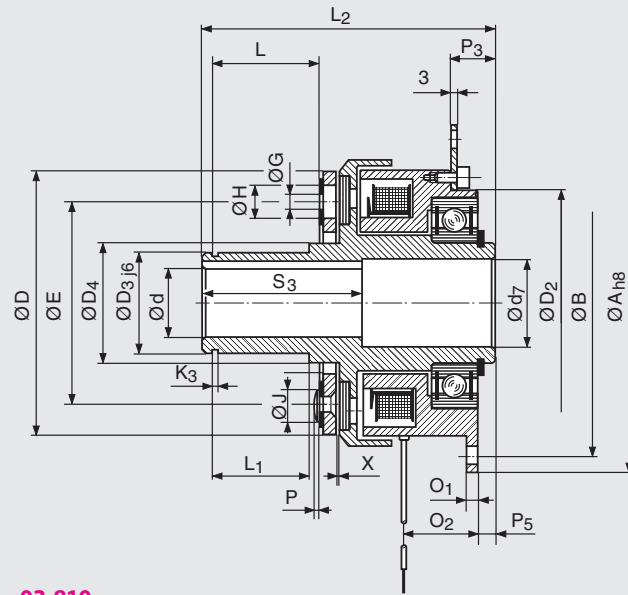
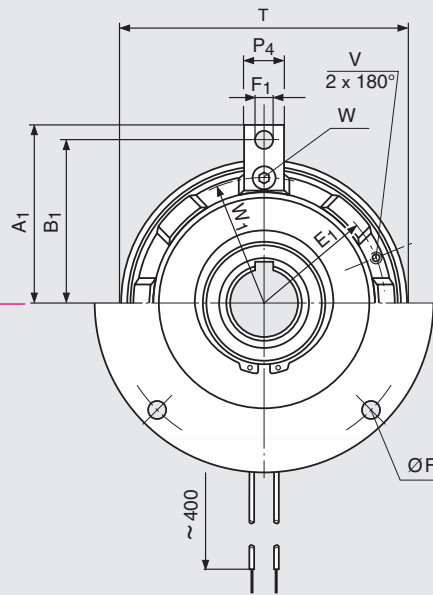

...03.810

available shaft diameters page 51

size	$M_{2N}^{1)}$ [Nm]	P_{20} [W]	$M_A^{2)}$ [Nm]	A_{hb}	A_1	B	B_1	C_5	D	D_2	D_3	D_4	d_4 max	d_7 max	E	E_1	E_2	F	F_1	G	H	J	
06	7	15	10	80	-	72	-	30	63	-	25	29	19	17	16	50	-	44	4x4.5	-	3x4.1	10	8
07	15	20	25	100	-	90	-	40	80	-	35	40	26	25	22	60	-	68	4x5.5	-	3x4.1	11	8
08	30	28	25	-	62.5	-	56	45	100	85	40	46	30	28.5	25	76	45.75	80	-	6.5	3x5.1	11.5	10
09	65	35	50	-	75	-	68.5	60	125	95	50	57	38	33	35	95	55	100	-	6.5	3x6.1	15	11.5
10	130	50	140	-	95	-	87.5	85	160	126	70	76	55	41	50	120	72.5	140	-	9	3x8.1	21	14.5
11	250	68	220	-	115	-	107.5	100	200	126	70	76	65	48	50	158	88	165	-	9	3x10.1	25	17.5
12	500	85	500	-	145	-	135	125	250	160	80	89	85	52	60	210	110	215	-	11	4x12.1	28	20.5

All dimensions in mm keyway according to DIN 6885/1-P9 Standard voltage 24 V DC VDE 0580, ISO-class „B“
¹⁾ rated torque after running in process ²⁾ tightening torque for W_2

For **flexible clutches** (type ...03.840) the following additional instructions are applicable:

The radial and axial screws connecting the rubber element to the hubs must all be tightened to the torque ($M_A^{2)}$) given in the table, using a torque wrench.
 Ensure that when tightening the screws the aluminium bushes do not twist in the rubber part and that they sit squarely. In order to reduce friction between the screw head and the aluminium bush smear a small amount of grease under the head of the screw before fitting. If necessary use a suitable tool to apply counter pressure on the element to prevent twisting of the rubber part while tightening the screws. This is particularly important with the radial screws otherwise the curved faces between the aluminium bush and the hub will not engage on the full area but only across the two sides. This will inevitably lead to slackening of the screws and destruction of the clutch. If the clutch is supplied in a pre-assembled state, do not dismantle it, but fit it in this condition.

shaft mounted clutches with flexible clutches

COMBINORM C
...03.840...

design torque support

size 08... 12

size 06 + 07

design flange

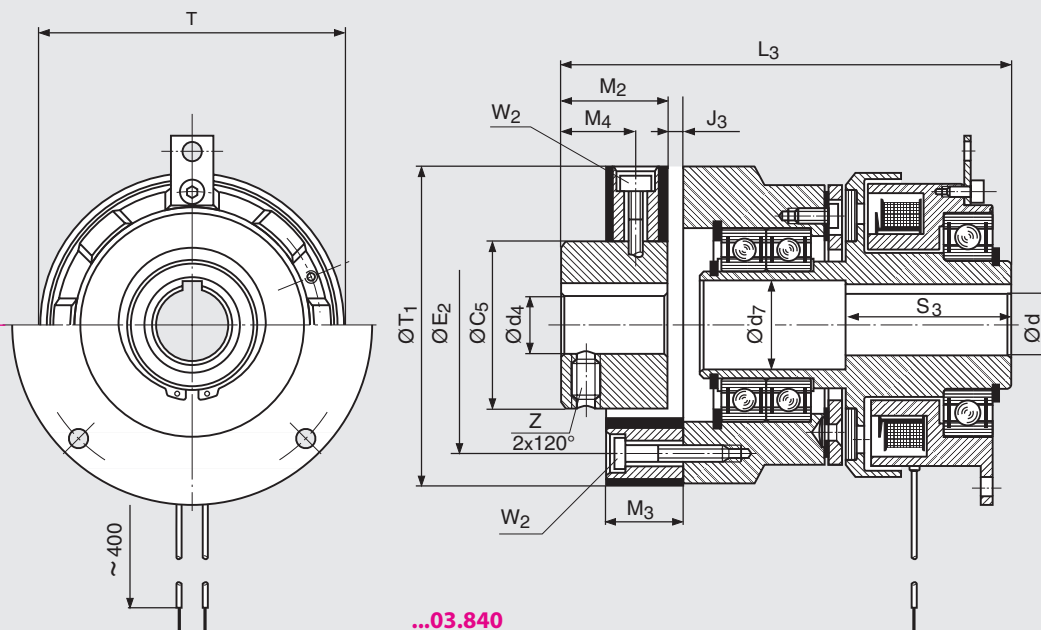

J ₃	K ₃	L	L ₁	L ₂	L ₃	M ₂	M ₃	M ₄	O ₁	O ₂	P	P ₃	P ₄	P ₅	S ₃	T	T ₁	V	W	W ₁	W ₂	X	Z	weight [kg]	
																								810	840
2	1.3	32.9	25.6	80	117	30	24	19	3	19	2	-	-	4	41	67	56	-	-	-	2xM 6	0.2	M 5	1	1.7
4	1.6	37.7	29.9	90	129	30	24	20	3	21.5	2	-	-	4.5	45	85	85	-	-	-	2xM 8	0.2	M 6	1.8	3
4	1.85	35.2	32.15	96	141	35	28	23	-	24	2.5	16.2	12	5.5	51.5	106	100	M 5	M 4	46.5	3xM 8	0.2	M 8	2.7	4.1
4	2.15	37.6	34.6	103	160	45	32	31	-	25	3	18.7	14	5.5	55	133	120	M 8	M 5	55	3xM 10	0.3	M 10	4.2	7.4
6	2.65	47.8	43.1	126	200	60	46	40	-	31.5	4	21.5	14	7	65	169	170	M 8	M 5	72.5	3xM 14	0.3	M 10	8.3	14.6
8	2.65	47.5	43.3	134	217	65	58	40	-	32.5	4.5	23	20	7	82	212.5	200	M 10	M 6	88	3xM 16	0.4	M 12	14.5	24.4
8	2.65	59.6	55.3	162	260	80	70	49	-	41	5	27	22	8	85	266	260	M 10	M 8	110	3xM 20	0.4	M 12	26	45.2

size	Compliance [mm] of flexible clutches	
	radial	axial
06	1.5	2
07	1.5	3
08	1.5	3
09	2	4
10	2	5
11	2	5
12	2	5

shaft mounted tooth clutches

COMBINORM T
...07.XX0...

design torque support

size 08... 10

size 06 + 07

design flange

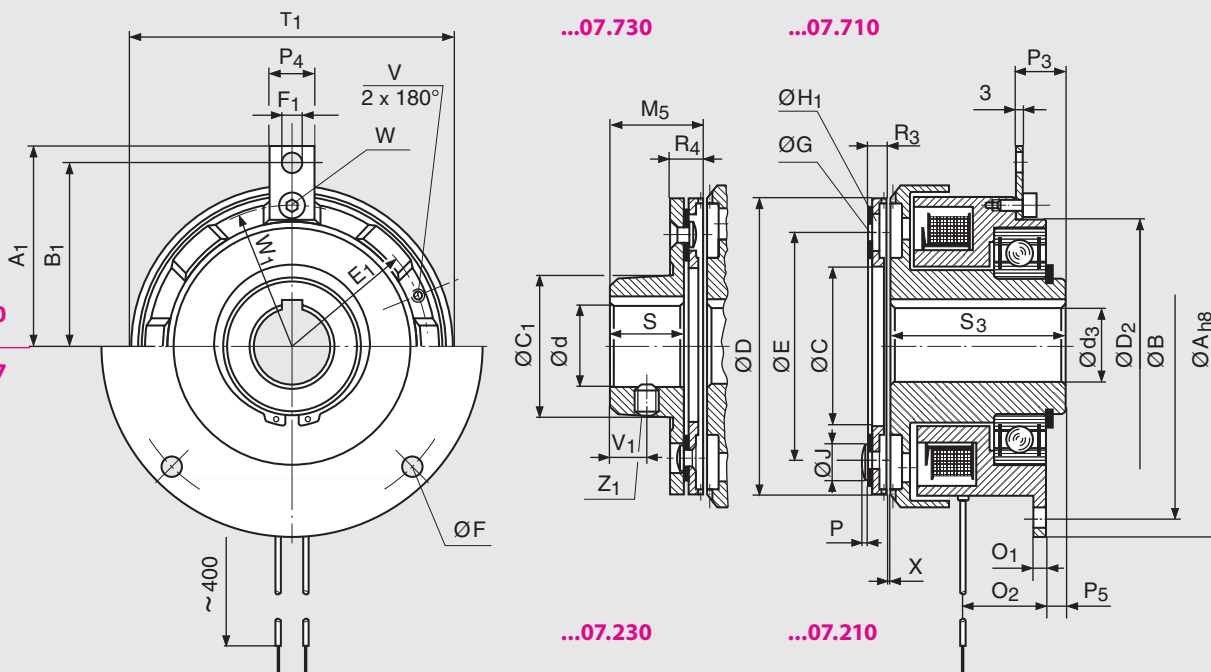

available shaft diameters page 51

size	M _{2N} [Nm]	P ^{20°C} [W]	A _{h8}	A ₁	B	B ₁	C ^{H8}	C ₁	C ₂	D	d ₁ max	D ₂	d ₃ max	d max	E	E ₁
06	21	15	80	-	72	-	35	32	36	63	20	-	17	18	50	-
07	45	20	100	-	90	-	42	38	43.5	80	25	-	22	22	60	-
08	90	28	125	62.5	112	56	52	48	53.8	100	30	85	30	30	76	45.75
09	195	35	150	75	137	68.5	62	58	63.8	125	35	95	35	35	95	55
10	390	50	190	95	175	87.5	80	73	82.1	160	50	126	50	45	120	72.5

size	F	F ₁	G	H ₁	J	K	K ₁	M ₅	N ₁	O	O ₁	O ₂	P	P ₃	P ₄	P ₅
06	4x4.5	-	3x4.1	8	8	3.5	1.6	20.3	24	6	3	19	2	-	-	4
07	4x5.5	-	3x4.1	8	8	4.25	1.85	26.4	26.5	7	3	21.5	2	-	-	4.5
08	4x6.6	6.5	3x5.1	11.2	10	5	2.15	33.6	30	8	4	24	2.5	16.2	12	5.5
09	4x6.6	6.5	3x6.1	15	11.5	5.5	2.15	41.2	33.5	9	4	25	3	18.7	14	5.5
10	4x9	9	3x8.1	16	14.5	6	2.65	50.8	37.5	11	5	31.5	4	21.5	14	7

size	R ₃	R ₄	S	S ₁	S ₃	T ₁	V	V ₁	W	W ₁	X	Z ₁	weight [kg]			
													210/710	230/730	110	130
06	5.3	8.8	15	22	41	68	-	6	-	-	0.15	1xM 6	1	1	0.7	0.7
07	6.4	10.4	20	24	45	86.5	-	8	-	-	0.2	1xM 6	1.7	1.8	1.1	1.2
08	8.6	13.6	25	27	51.5	108	M5	10	M 4	46.5	0.2	1xM 8	2.6	2.8	1.9	2.1
09	11.2	17.2	30	30	55	135	M8	12	M 5	55	0.2	2xM10	4.1	4.4	3.2	3.5
10	12.8	19.8	38	34	65	172.2	M8	15	M 5	72.5	0.25	2xM10	7.5	8.3	6.1	6.9

All dimensions in mm keyway according to DIN 6885/1-P9 Standard voltage 24 V DC VDE 0580, ISO-class, B*

COMBINORM

Technical data

Combinorm 02 / 03 / 04 / 07				01	02	03	05	06	07	08	09
size											
$M_{2N}^{1)}$	02/03/04	20°	[Nm]	0.5	0.75	1.5	3	7	15	30	65
	07							21	45	90	195
P_{20}	02/04 brake	20°	[W]	6	6	8	10	12	16	21	28
	03/04/07 clutch	20°		6	6	8	10	15	20	28	35
J											
armature	110/210/610/710/810		[10 ⁻⁴ kgm ²]	0.010	0.014	0.045	0.122	0.366	1.07	3.72	10.6
	120/130/230/630/730			0.013	0.021	0.068	0.18	0.53	1.57	5.29	15.1
	320							0.82	2.6	10.3	27
	170							0.99	2.7	9.12	25.4
Rotor	110/130/140/170/610			0.025	0.035	0.15	0.375	0.825	2.38	7.25	21.9
	630/640										
	210/230/240/710/730/740			0.027	0.038	0.17	0.4	0.9	2.6	8	24
	810						1.02	3.05	8.76	26	
$W_{Rmax.}$	02/03/04		[10 ⁴ J]	0.04	0.05	0.08	0.12	0.19	0.31	0.48	0.75
$W_{R0,1mm}$	02/03/04		[10 ⁷ J]	0.23	0.3	0.43	0.63	0.95	1.63	2.53	4.09
$P_{Rmax.}$	02/04 brake		[J/s]	12.8	18.6	26.9	38.9	58.3	79.2	114	164
	03/04 clutch			20.3	28.6	40.6	58.3	80.6	114	161	228
$X_{nmax.}$ 20°	02/03/04		[mm]	0.3	0.45	0.45	0.6	0.7	0.7	0.7	0.9
	07							0.15	0.2	0.2	0.2
X	02/03/04			0.1	0.15	0.15	0.2	0.2	0.2	0.2	0.3
	02/03/04/07		[rpm]	10000	10000	10000	10000	8000	6000	5000	4000
$n_{max.}$	exception clutch!			1500	1500	1500	1500	1500	1500		
	03.610/630/640										
switching times											
brake 02/04	t_2 DC	[ms]		3	4	5	8	10	15	50	85
				17	20	25	40	70	95	240	300
	rated torque	$t_{11} =$		2	3	3	5	6	8	10	13
			$t_1 =$	5	8	8	17	24	38	42	48
	3 x rated torque	$t_{11} =$		1	2	2	3	3	4	5	6
			$t_1 =$	3	4	4	8	11	17	20	22
clutch 03/04	t_2 DC	[ms]		5	6	7	10	14	19	40	68
			t_2 AC	17	19	22	30	39	61	115	220
	rated torque	$t_{11} =$		4	5	7	10	14	18	23	25
			$t_1 =$	10	14	17	32	48	74	81	90
	3 x rated torque	$t_{11} =$		2	2	3	5	6	8	10	12
			$t_1 =$	5	6	7	16	22	33	37	42

Legend

$M_{2N}^{1)}$ rated torque after running in process

M_{erf} required torque

J moment of inertia

P_{20} power at 20° C

n_{max} maximum speed

X rated air gap

X_n clearance at which an adjustment is recommended

W_{Rmax} permissible friction per switching operation

$W_{R0,1}$ friction work up to 0,1 mm wear

P_{Rmax} permissible friction work per second

I magnet-rated current

t time

[Nm]

[Nm]

[10⁻⁴kgm²]

[W]

[min⁻¹]

[mm]

[mm]

[10⁴J]

[10⁷J]

[J/s]

[A]

[ms]

t_1

t_{11}

t_2

Engaging time Time from connecting the current until the torque rises

Engaging delay time: Time from connecting the current until the torque rises

Release time: Time from disconnecting the current until 0.1 M_{2N}

COMBINORM

10	11	12
130	250	500
390		
38	50	65
50	68	85
40	115	311
50.1	159	437
101		
88.9	272	814
67.4	200	450
73	220	500
82.5	230	520
1.25	2	2.9
6.66	10.4	16.3
236	339	489
322	458	647
1.0	1.2	1.2
0.25		
0.3	0.4	0.4
3000	3000	2000
100	140	200
400	600	800
15	23	35
85	118	155
8	10	16
38	50	76
100	130	200
400	650	900
29	37	55
161	201	295
14	16	25
69	91	125

DC-side switching

Current / time and torque / time diagrams

The mentioned designations of switching times are according to DIN VDE 580.

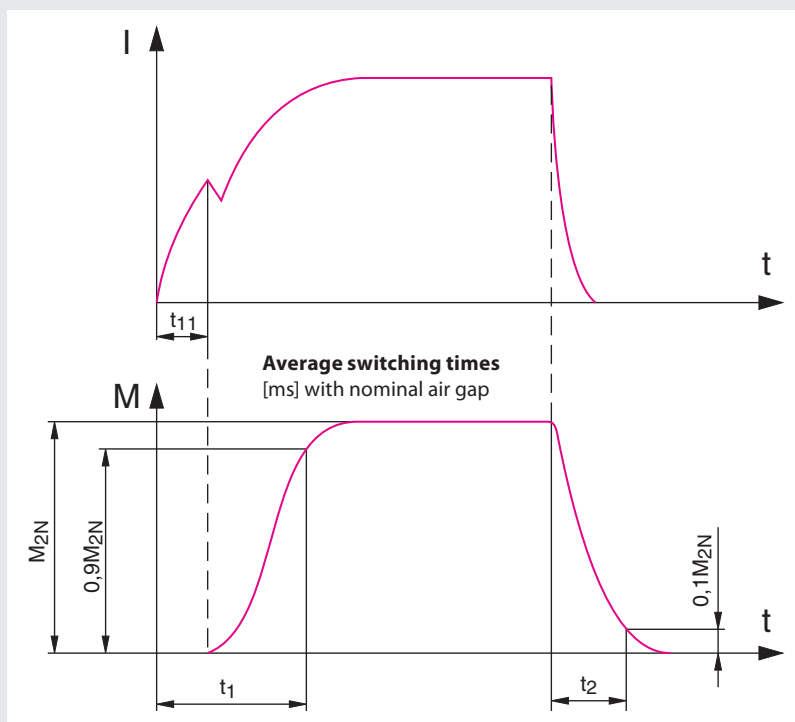

The specified switching times are achieved with adjusted nominal air gap (x_{min}). It concerns average values whose scattering depends on the current supply and the coil temperature.

The torques specified in the measuring tables are safely achieved with single-side clutches and brakes after a run-in phase at 100 rpm. In new condition and in case of substantially higher speeds the torques are possibly smaller

Current supply

The **COMBINORM** requires a DC voltage, which can be made available by different rectifiers, transformer rectifiers as well as electronic switches of the series **COMBITRON 91, 92 and 94**.

A short-time overvoltage produces very short switching times and high switching accuracies.

ent
[ms]
he
[ms]
rent
[ms]

Program Schedule

COMBIBOX

clutch-brake-combination type **10 / 09 / 06**

with an energised to engage single sided clutch / brake COMBIBOX **10**

with an energised to engage single sided clutch without brake COMBIBOX **09**











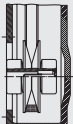
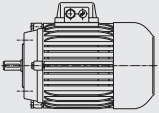
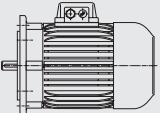





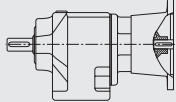



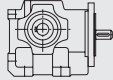

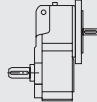

with an energised to engage single sides clutch / and energised to disengage single sided permanent magnet brake COMBIBOX **06**

Technical data: Moment of inertia, friction work and calculationspage 42

On request we adapt the **COMBIBOX** to your constructional and electrical requirements.

Design

Attachments

	input					
output						
			360 / 370	380 / 390	460 / 470	440
						
			570 / 580	410 / 430	450 / 480	670
						
			490	500	510	520
						
			530 / 540	550 / 560	590 / 600	610
						
			620 / 630	640 / 660	700	800

The **COMBIBOX** is a ready to install electromagnetic actuated clutch-brake module in a single housing.
 The modular system is designed for a multitude of variants; these covering most of the applications in the field.
 The patented adjustment procedure permits an air gap re-adjustment in it's installed condition. Thus giving a greater lifetime of the wear affected components.

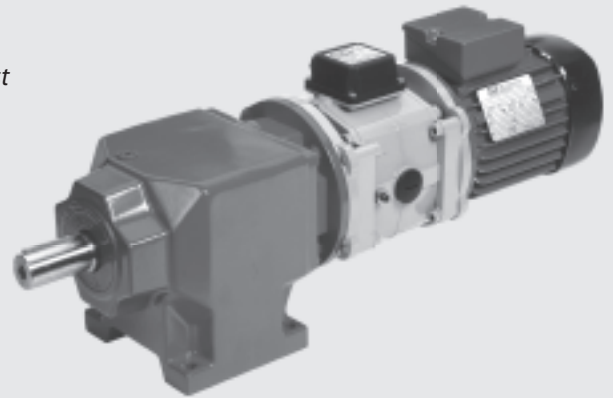

The units designed for Start-Stop-operation considerably reduce the energy consumption due to a continuously running drive.

type 10

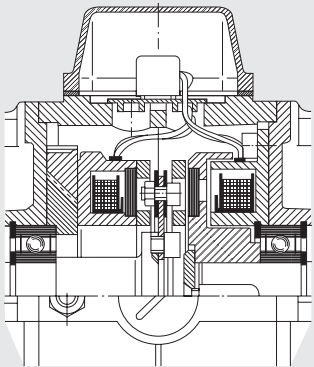

has an **energise to engage single sided brake**, this is the most commonly used, permitting high switching frequency and good positioning accuracy. The **COMBITRON** rapid switch can be used with this variant to achieve exceptionally high switching frequencies.
 The rated torque of both clutch and brake are identical.

type 09

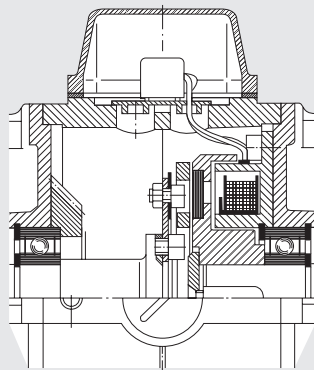

is the **COMBIBOX** version **without brake**, i.e. an electrical clutch in a housing for the use between e.g. motor and gear unit.

type 06

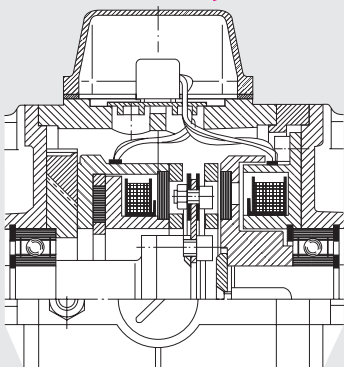

has an **energise to disengage permanent magnet single-side brake**. The characteristic of this variant is that the position of the output shaft is kept safe and backlash-free in currentless condition. The rated torque of the brake is slightly lower than that of the clutch.

COMBIBOX shaft in / shaft out

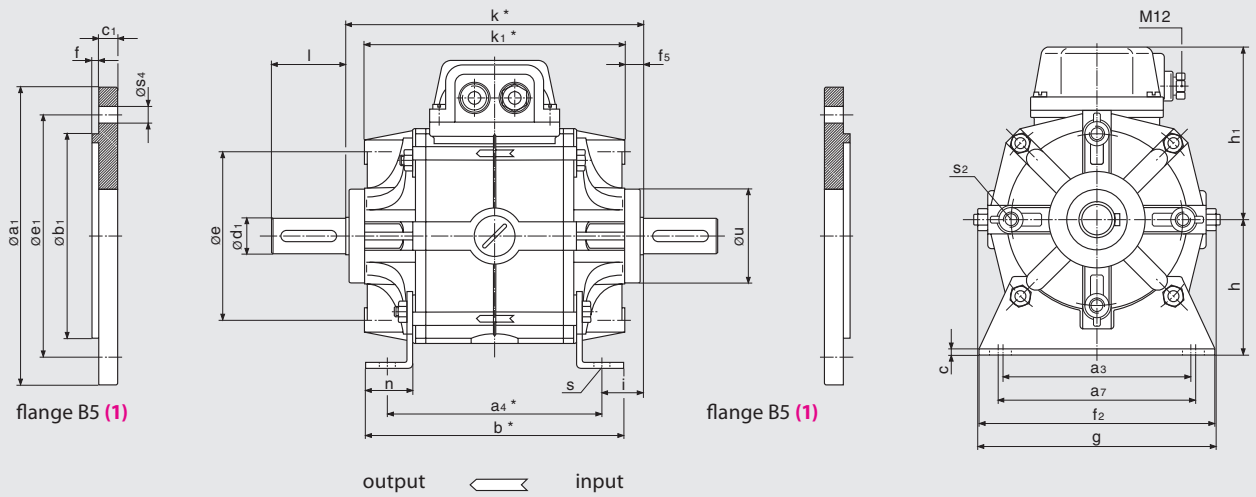

flange dimensions page 43

size	a_3	a_4	a_7	b	c	e	f_2	f_5	g	h	h_1	i	k	k_1	n	s	s_2	u	shaft			weight [kg]	
																			d_1	l			
06	80	100/109	85	115/124	3	72	100	10	103	63	87	18.4	137/146	117/126	18	7	M6	44	11	14	23	30	2.8/2.9
07	105	115/125	110	138/148	3	90	130	10	125	71	94	22.7	160/170	140/150	25	9	M8	50	14	19	30	40	3.9/4.1
08	130	135/147	140	160/172	4	112	160	12	158	90	108	30.6	196/208	172/184	28	9	M8	62	19	24	40	50	7.7/8.7
09	150	155/169	160	180/194	5	137	180	14	185	100	129	34.4	224/238	196/210	30	11	M10	74	24	28	50	60	12.5/15.0
10	185	185/202	195	215/232	6	175	223	18	236	132	154	50.6	286/303	250/267	38	13	M12	95	28		60		22.5/28.0
11	upon request																						

rated torques 10 / 09 / 06

variations type 06 (marked in red)

size	06	07	08	09	10	11	
$M_{2N}^{1)}$ [Nm]	clutch	7	15	30	65	130	250 / -
	brake	7 / 6	15 / 12	30 / 24	65 / 50	130 / 120	250 / -
P_{20} [W]	clutch	15	20	28	35	50	68 / -
	brake	12 / 13	16 / 21	21 / 20	28 / 30	38 / 50	50 / -

all dimensions in mm keyways according to DIN 6885/1 centerings D according DIN 332/2 Standard voltage 24 V DC VDE 0580, ISO-class „B“
¹⁾ rated torque after running in process

part no.	feet	input flange B5 (1)	output flange B5 (1)
---.---.360			
---.---.370	X		
---.---.380		X	
---.---.390	X	X	
---.---.410		X	X
---.---.430	X	X	X
---.---.570			X
---.---.580	X		X

design type size

ordering specification:

- part number
- diameter of input-side flange
- diameter of input-side shaft
- diameter of output-side bore
- diameter of output-side flange
- operating voltage of COMBIBOX
- flange dimensions on page 43

Ordering example:

size 06. 10. 430 design
 type

V DC, $\varnothing a_1$, $\varnothing d_1$?

COMBIBOX bore in / bore out

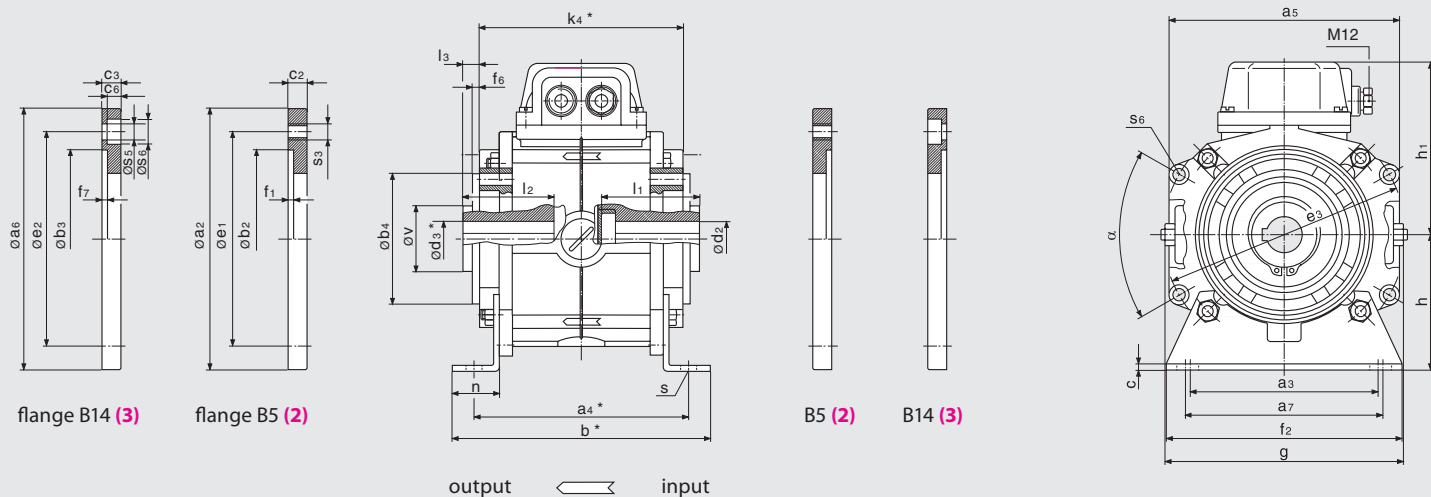

flange dimensions page 43

size	a_3	a_4	a_5	a_7	b	b	c	d_2	d_3	e_3	f_2	f_6			Preferential-bore d_2 and d_3
06	80	100/109	104	85	115/124	60	3	15	15	108	100	4			11 or 14
07	105	115/125	123	110	138/148	70	3	24	24	128	130	4			14 or 19
08	130	135/147	155	140	160/172	80	4	28	28	165	160	4			19 or 24
09	150	155/169	178	160	180/194	95	5	35	35	190	180	5			24 or 28
10	185	185/202	229	195	215/232	110	6	42	42	242	223	5			28
11	upon request														

variations type 06 (marked in red)

size	g	h	h_1	k_4	l_1	l_2	l_3	n	s	s_6	v	α			weight [kg]
06	103	63	87	101 / 110	50	57	9	18	7	5.5	30	60			2.7 / 3.1
07	125	71	94	108 / 118	52	61	9	25	9	6.5	35	60			3.7 / 4.5
08	158	90	108	132 / 144	63.5	75	11	28	9	8.5	45	64			7.5 / 8.9
09	185	100	129	153 / 167	74	86	13	30	11	8.5	50	62			12.0 / 14.5
10	236	132	154	175 / 232	86	102	17	38	13	10.5	70	60			20 / 25.5
11	upon request														

all dimensions in mm keyways according to DIN 6885/1 centerings D according DIN 332/2 Standard voltage 24 V DC VDE 0580, ISO-class „B“

part no.	feet	input flange		output flange	
		B5 (2)	B14 (3)	B5 (2)	B14 (3)
---.---.510			X	X	
---.---.520		X		X	
---.---.590			X		X
---.---.600	X		X		X
---.---.610		X			X
---.---.680					
---.---.690	X				
---.---.					

design
type
size

ordering specifications:

- part number
- diameter of input-side flange
- diameter of input-side shaft
- diameter of output-side shaft
- diameter of output-side flange
- operating voltage of COMBIBOX
- flange dimensions page 43

Ordering example:

size 06. 10. 600 design
type

V DC, $\varnothing a_e$, $\varnothing d_2$, $\varnothing a_e$, $\varnothing d_3$?

COMBIBOX bore in / shaft out

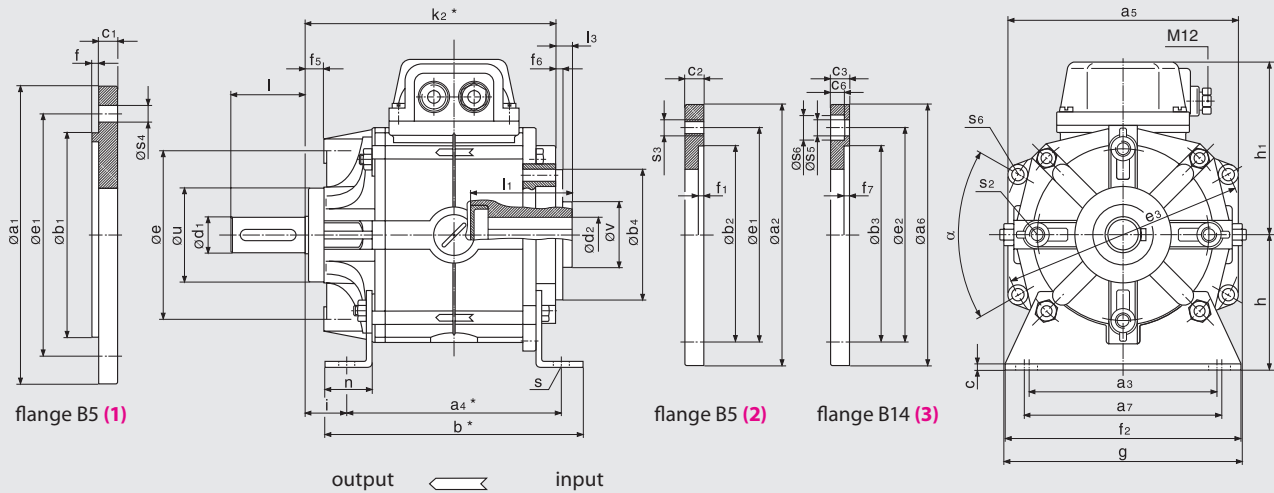

flange dimensions on page 43

size	a ₃	a ₄	a ₅	a ₇	b	b ₄ h8	c	d ₂₊₃ G7 max	e	e ₃	f ₂	f ₅	f ₆	g	h	h ₁	i	k ₂
06	80	100/109	104	85	115/124	60	3	15	72	108	100	10	4	103	63	87	18.4	119/128
07	105	115/125	123	110	138/148	70	3	24	90	128	130	10	4	125	71	94	22.7	134/144
08	130	135/147	155	140	160/172	80	4	28	112	165	160	12	4	158	90	108	30.6	164/176
09	150	155/169	178	160	180/194	95	5	35	137	190	180	14	5	185	100	129	34.4	189/203
10	185	185/202	229	195	215/232	110	6	42	175	242	223	18	5	236	132	154	50.6	231/248
11	upon request																	

all dimensions in mm keyways according to DIN 6885/1 centerings D according DIN 332/2 Standard voltage 24 V DC VDE 0580, ISO-class „B“

rated torques 10 / 09 / 06

size	06	07	08	09	10	11
M _{2N} ¹⁾ [Nm] clutch	7	15	30	65	130	250 / -
brake	7 / 6	15 / 12	30 / 24	65 / 50	130 / 120	250 / -
P ₂₀ [W] clutch	15	20	28	35	50	68 / -
brake	12 / 13	16 / 21	21 / 20	28 / 30	38 / 50	50 / -

all dimensions in mm keyways according to DIN 6885/1 centerings D according DIN 332/2 Standard voltage 24 V DC VDE 0580, ISO-class „B“

¹⁾ rated torque after running in process

part no.	feet	input flange		output flange
		B5 (2)	B14 (3)	B5 (1)
.....440			X	
.....450		X		X
.....460			X	
.....470	X		X	
.....480		X		X
.....640				
.....660	X			
.....670				X

design type size

ordering specifications:

- part no.
- diameter of input-side flange
- diameter of input-side shaft
- diameter of output-side bore
- diameter of output-side flange
- operating voltage of COMBIBOX
- flange dimensions on page 43

ordering example:

size 06 10 450 design
type

V DC, Ø a_g, Ø d₂, Ø a₁, Ø d₁ ?

COMBIBOX shaft in / bore out

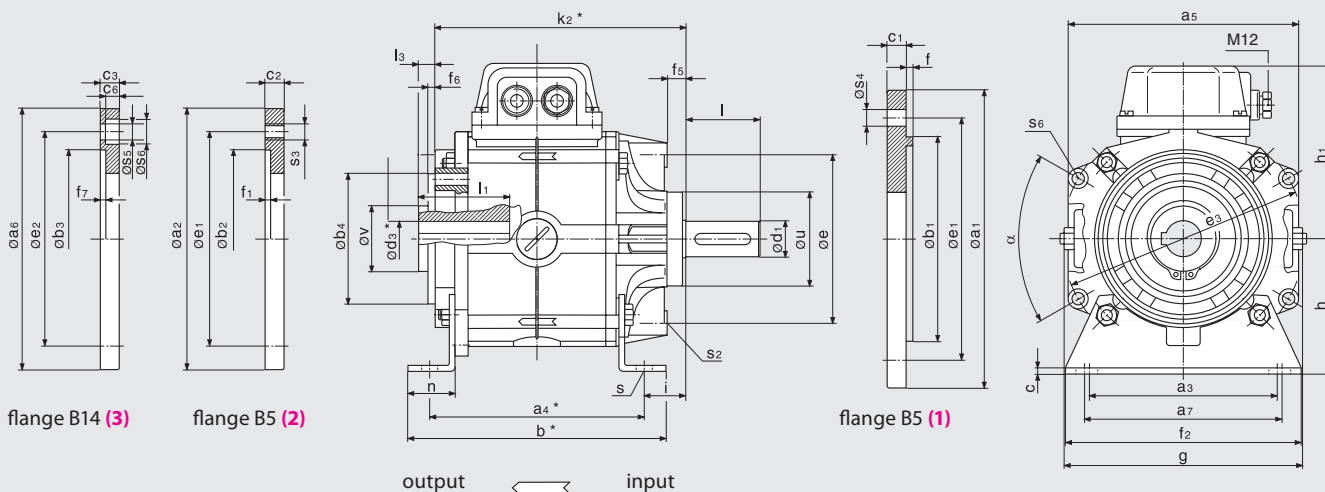

flange dimensions on page 43

l ₁	l ₃	n	s	s ₂	s ₆	u h8	v	α	Preferential bore	shaft		weight
									d ₂ and d ₃	d ₁ k6	l	[kg]
50	9	18	7	M6	5.5	44	30	60	11 or 14	11 14	23 30	2.8/3.1
52	9	25	9	M8	6.5	50	35	60	14 or 19	14 19	30 40	3.9/4.5
63,5	11	28	9	M8	8.5	62	45	64	19 or 24	19 24	40 50	7.7/8.9
74	13	30	11	M10	8.5	74	50	62	24 or 28	24 28	50 60	12.5/14.5
86	17	38	13	M12	10.5	95	70	60	28	28	60	22.5/26.0

variations type 06 (marked in red)

part no.	feet	input flange B5 (1)	output flange	
			B5 (2)	B14 (3)
---.---.490			X	
---.---.500		X	X	
---.---.530				X
---.---.540	X			X
---.---.550		X		X
---.---.560	X	X		X
---.---.620				
---.---.630	X			

design
type
size

ordering specifications:

- part no.
- diameter of input-side flange
- diameter of input-side shaft
- diameter of output-side bore
- diameter of output-side flange
- operating voltage of COMBIBOX
- flange dimensions on page 43

ordering example:

size 06. 10. 500 design
type

V DC, Ø a₁, Ø d₁, Ø a₂, Ø d₃ ?

Technical data

Combibox 06 / 09 / 10				06	07	08	09	10	11
size		type							
$M_{2N}^{2)}$	clutch	06/09/10	[Nm]	7	15	30	65	130	250
	brake	10		7	15	30	65	130	250
		06			6	12	24	50	120
P_{20}	clutch	06/09/10	[W]	15	20	28	35	50	68
	brake	10		12	16	21	28	38	50
		06			13	21	20	30	50
$J^{1)}$	rotor	06/09/10	$[10^{-4}kgm^2]$	1.07	2.98	7.78	23.29	67.4	220
	armature	06/09/10		0.84	2.62	8.59	23.08	91.07	330
	armature	09		0.80	1.2	4.8	12.61	54.3	190
W_{Rmax}		06/09/10	$[10^3J]$	1.9	3.1	4.8	7.5	12.5	20.0
$W_{R0,1mm}$	clutch	06/09/10	$[10^6J]$	9.5	16.3	25.3	40.9	66.6	104
	brake	06/10		9.5	16.3	25.3	40.9	66.6	104
$P_{Rmax.}$	clutch	06/09/10	[J/s]	81	114	161	228	323	458
	brake	06/10		59	80	114	164	236	339
X		06/09/10	[mm]	0.2	0.3	0.35	0.35	0.4	0.5
X_n		06/09/10	[mm]	0.4	0.6	0.7	0.7	0.8	1.0
n_{max}		06/09/10	[rpm]	3000	3000	3000	3000	3000	3000

switching times		type 09/10 rated voltage [ms]				type 06 rated voltage [ms]			
clutch		t_{11}	t_1	t_2		t_{11}	t_1	t_2	
brake			t_2	t_{11}	t_1	t_1		t_2	$t1$
size	06	18	55	15	45	20	50	10	45
	07	25	95	20	60	25	85	14	50
	08	40	125	30	110	40	100	22	68
	09	50	200	40	160	50	200	30	150
	10	60	250	45	220	85	250	40	180
	11	100	300	80	260				

$J^{1)}$	= moment of inertia	[kgm ²]	t_1	= Engaging time, time until 0.9 M_{2N} is reached	[ms]
$M_{2N}^{2)}$	= rated torque after running in process	[Nm]	t_{11}	= Engaging delay time, time until the armature is attracted	[ms]
P_R	= permissible friction per second	[J/s]	t_2	= Release time, time until the armature is attracted to the opposing side.	[ms]
P_{20}	= power input at 20 °C	[W]			
W_R	= friction	[J]			
$W_{R0,1}$	= friction work until an abrasion of 0,1 mm is reached	[J]			
X	= rated air gap	[mm]			
X_n	= clearance at which a readjustment is recommende	[mm]			

¹⁾ Sum of the moment of inertia reduced to the speed of the COMBIBOX plus the moment of inertia of the COMBIBOX parts to be accelerated or decelerated (J).

²⁾ The rated torques listed are safely attained after a run-in phase at 100 rpm. In new condition and for substantially higher speeds the torques are possibly lower.

Power supply

COMBIBOX requires d.c. voltage for actuation. The rated voltage of the magnets is 24 V DC standard. For operation with rectifiers the magnets are available in other voltages on specification.

The permanent-magnet brake installed in type 06 requires a smoothed supply voltage. To ensure a safe function in case of large temperature fluctuations, we recommend the supply of the coil with constant current.

Single-way or bridge rectifiers of the series COMBITRON 91 can be installed in the terminal box. Trafo rectifiers, electronic switches and rapid switches are also available.

Due to the exponential rise of the current in the coil the dynamic effect occurs delayed for all electromagnets. Therefore the full torque can be transmitted only after the time t_1 . Similar delays occur at switch-off.

COMBIBOX

size	IEC Ø ¹⁾	a1 (1)	a2 (2)	a6 (3)	b1 (1) h8	b2 (2) +0,3 +0,2	b3 (3) H8	c1 (1)	c2 (2)	c3 (3)	c6 (3)
06	90	90	105	105	60	60	60	10	10	10	5.5
	105	105	105	105	70	70	70	10	10	10	6.5
	120	120	120	120	80	80	80	10	10	10	6.5
	140	140	140	140	95	95	95	10	10	12	8.0
	160	160	160	160	110	110	110	10	12	12	8.0
07	105	110	120	120	70	70	70	10	10	10	6.5
	120	120	120	120	80	80	80	10	10	10	6.5
	140	140	140	140	95	95	95	10	10	10	6.0
	160	160	160		110	110		10	12		6.0
	200	200	200		130	130		10	14		8.0
08	120	130	-	160	80		80	12		12	6.5
	140	140	160	160	95	95	95	12	12	12	6.0
	160	160	160	160	110	110	110	12	12	12	6.0
	200	200	200	200	130	130	130	12	14	14	7.0
	250	250	250	-	180	180		12	14		
09	140	160	160	160	95	95	95	14	14	14	9.0
	160	160	160	160	110	110	110	14	14	14	9.0
	200	200	200	200	130	130	130	14	14	14	
	250	250	250	250	180	180	180	14	14	14	
10	160	-	200	200		110	110		18	18	9.0
	200	210	200	200	130	130	130	18	18	18	8.0
	250	250	250		180	180		18	18		
	300	300	300		230	230		18	18		
	350	350			250			20			
11	250	250	268		180	180		20	25		
	300	300	300		230	230		20	25		
	350	350	350		250	250		20	25		
size	IEC Ø ¹⁾	e1 (1 + 2)	e2 (3)	f (1)	f1 (2)	f7 (3)	s3 (2)	s4 (1)	s5 (3)	s6 (3)	weight [kg] (1/2/3)
06	90	75	75	2.5	3	3	M5	5.5	5.5	10	0.16
	105	85	85	2.5	3.5	3	M6	7.0	6.5	11	0.17
	120	100	100	3	3.5	3.5	M6	6.5	6.5	11	0.2
	140	115	115	3	3.5	3.5	M8	9	8.5	14	0.28
	160	130	130	3.5	4	4	M8	9	8.5	14	0.45
07	105	85	85	2.5	3.5	3	M6	M6	6.5	11	0.21
	120	100	100	3	3.5	3.5	M6	6.5	6.5	11	0.22
	140	115	115	3	3.5	3.5	M8	9	9	14	0.3
	160	130		3.5	4		M8	9		14	0.33
	200	165		3.5	4		M10	11		18	0.55
08	120	100	100	3		3.5		7	6.5	11	0.45
	140	115	115	3	3.5	3.5	M8	9	9	14	0.48
	160	130	130	3.5	4	4	M8	9	9	14	0.5
	200	165	215	3.5	4	4.5	M10	11	14	18	0.8
	250	215		4	4.5		M12	14			1.4
09	140	115	115	3		3.5		9	9	15	0.5
	160	130	130	3.5	4	4	M8	9	9	15	0.55
	200	165	165	3.5	4	4	M10	11	11		0.63
	250	215	215	4	4.5	4.5	M12	14	14		0.95
10	160		130		4.5	4.5	M8		9	15	0.9
	200	165	165	4	4.5	4	M10	11	11	18	1.1
	250	215		4	4.5		M12	14			1.2
	300	265		4	5		M12	14			1.25
	350	300		5				18			6.5
11	250	215		4	4.5		M12	14			
	300	265		4	4.5		M12	14			
	350	300		5	5.5		M16	18			

¹⁾ according DIN IEC 34

standard flange

COMBITRON

are supply and actuator modules for the electromagnet clutches and brakes. As power supply for DC- or AC-side switching different single-wave and bridge rectifiers as well as rapid switchgear of the series **COMBITRON** are available.

The rectifiers correspond to the low voltage regulation 73/231/EWG of the European Union.

Program Schedule

COMBITRON Rectifiers and Switches

Half-wave and bridge rectifiers from 0 - 720 V AC	page 44	COMBITRON	91
Electronic rapid switch up to 50 W	page 46	COMBINORM	94
Rapid-switching rectifier (for COMBISTOP)	page 47	COMBINORM	98

Technical data

Switching mode (AC- / DC-side switching)	page 48
--	---------

COMBITRON 91

Rectifiers for power supply of brakes and clutches. AC voltage supply max 720VAC for AC or DC side switching conform to the low voltage regulation 72/231 EWG of the European Union.

Harmful electromagnetic interferences arise at the switching of electromagnetic clutches and brakes and other inductive DC consumers.

The half-wave rectifier 02.91.010-CEMV limits these interferences to class A according to EN 55011.

All other rectifiers are not equipped with measurements to suppress radio interference. This has to be taken into consideration for the planning of the interference suppression of the plant or the machine. The user is responsible for meeting the EU machine directive.



COMBITRON 91

UL:

	300 V	300 V	300 V	100 V
U_{in} switching	275 VAC +0%	500 VAC +0%	600 VAC +0%	720 VAC +0%
U_{vmax}	450 V	900 V	1000 V	1600 V

half wave
 $U_{out} = 0,45 \cdot U_{in}$
 $I_N(45^\circ C) = 1,0A$
 $I_N(80^\circ C) = 0,5A$

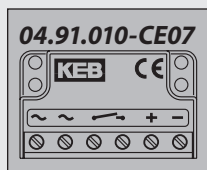

full wave
 $U_{out} = 0,9 \cdot U_{in}$
 $I_N(45^\circ C) = 2,0A$
 $I_N(80^\circ C) = 1,0A$

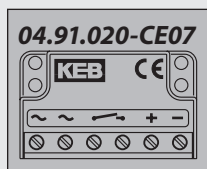
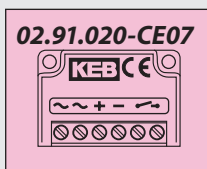

U_{in} maximum input voltage
 U_{vmax} maximum switch-off voltage
 U_{out} DC output voltage
 AC AC side switching
 DC DC side switching
 $I_N(45^\circ C)$ nominal current at stated temperature

half wave with EMC protection¹⁾
 $U_{out} = 0,45 \cdot U_{in}$
 $I_N(45^\circ C) = 1,0A$
 $I_N(80^\circ C) = 0,5A$

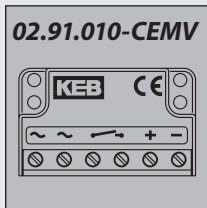

Characteristics

- compact design in a plastic housing
- possible installation into the motor terminal box
- protection against voltage peaks of the switching contacts
- maximal ambient temperature 80° C

¹⁾ with internal interference suppression according to EN 55011/ class A

Nominal voltage magnet	Coil voltage tolerance $U_2 (U_{out})$	AC voltage supply $U_1 (U_{in})$	Type of rectifier	
24 V DC				
105 V DC	93 - 118	230 V AC	half wave rectifier	(02.91.010-CE07)
205 V DC	182 - 230	230 V AC	full wave rectifier	(02.91.020-CE07)
180 V DC	162 - 198	400 V AC	half wave rectifier	(04.91.010-CE07)

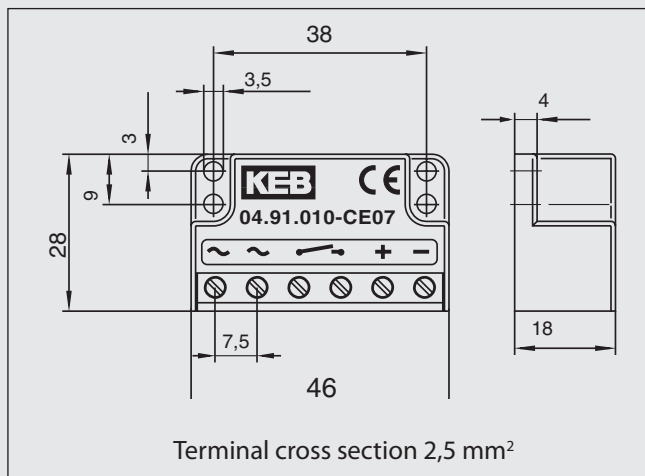
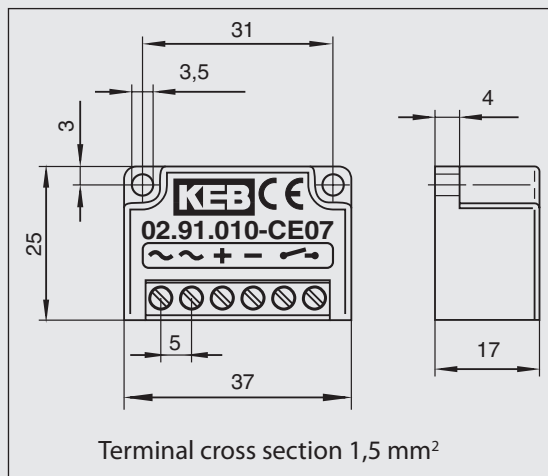

COMBITRON 94

for the power supply / actuator of two consumers.

The output current control ensures a constant magnetic flux and permits short-time overexcitations for shorter switching processes, i.e. improved repeat accuracy. The main field of application is the interconnection of clutch-brake-combinations COMBIBOX and is used whenever high switching frequencies and positioning accuracy are demanded. The primary feature is the current regulation of 24 V DC supply of electromagnets.

Features

- circuit board is supplied inclusive holder and slide-in device
- connection according to DIN 41612
- adjustment of the deceleration time by potentiometer from 0 ... 1 second
- power supply of the circuit board via separate transformer
input voltage: 230/400/460 V AC
- power range 15 ... 50 W
- digital inputs
- relay output

switcher 00.94.006-0004
transformer 00.94.006-0100

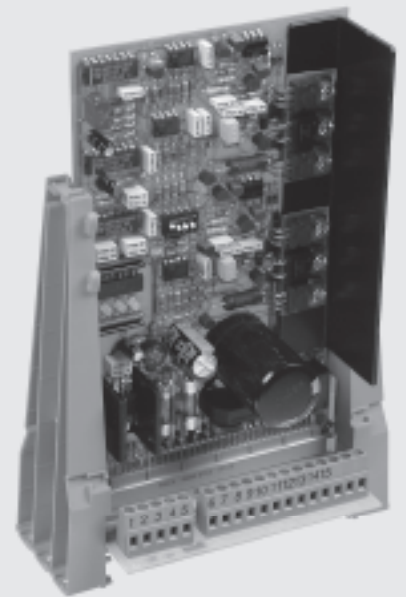

COMBITRON 98

Rapid-switching rectifiers with overexcitation for optimal turn-on and turn-off times of spring-applied brakes and electromagnets.



In dependence on supply and coil voltage following advantages are the result:

230 V AC Input voltages 105 V DC coil

- short release time compared to normal excitation and connection to half-wave rectifiers
- wear capacity is doubled (wear until adjustment of the air gap)

230 V AC Input voltage 205 V DC coil

- short engaging time (-30%) due to small holding voltage
- the holding voltage of 105 V is sufficient to retain the armature. The power is reduced to 25 % thus causing less heating.

180 - 264 V AC Input Voltage 130 V DC coil

- insensitive to voltage fluctuations from the mains, yet still providing safe functioning of the brake. In dependence on the actual mains voltage it results in the additional advantages listed above.

Electric characteristics	
Input voltage	180 - 300 V AC +/- 0%
Overexcitation time	350 ms +/- 10%
cable length	max. 100 m to the brake coil
current I_N 45° C	1,2 A continuous; 2,4 A for 350 ms
current I_N 75° C	0,7 A continuous; 1,4 A for 350 ms

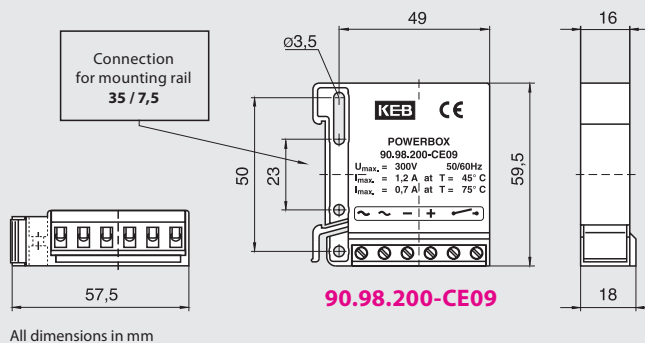

Features

- fast mounting through integrated connection for mounting rails
- easy handling due to fixed overexcitation time
- compact design in plastic housing
- AC- and DC-side switching possible
- when connecting to AC voltage it replaces half-wave respectively bridge rectifiers
- max. ambient temperature 75° C

Switching Arrangements

AC-side Switching

When switching before the rectifier on the AC-side the magnetic field decays slowly. At this mode of switching the tripping delay is quite long. The AC-side switching requires no protective measurements for the coil and the switching contacts. On disconnection the rectifier diodes act as free-wheeling diodes.

The switching times t_{11} for AC-side switching increase when the rectifier is connected directly in the motor terminal box **(2)**. When the motor slows down a generative voltage is applied to the motor terminals. The wiring **(2 and 3)** is not permitted for frequency inverter operation.

For line lengths of more than 10 m between rectifier and brake at AC-side switching the regulations prescribe the use of a separate switch **(1)**. In this case the supply voltage may not be tapped behind the motor contactor **(2)**. If it is not possible to install an additional switch the use of special rectifiers becomes necessary.

Current-time-/Voltage-time-/Torque-time-diagram

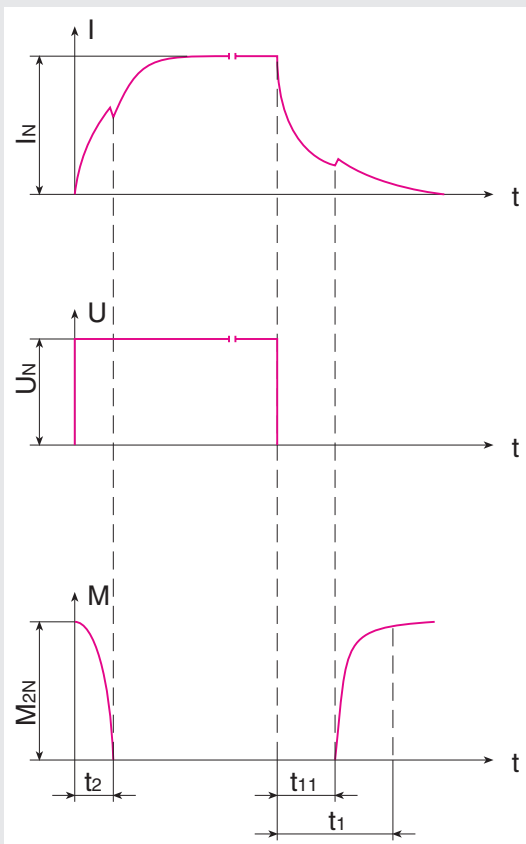

- t_1 = Engagement time
- t_{11} = Engagement delay time
- t_2 = Release time

Wiring diagram

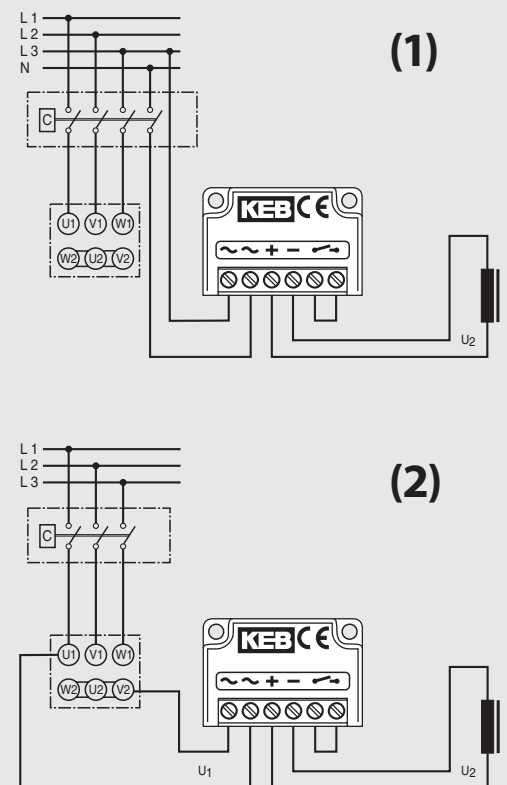

DC-side switching

The switching is done between the rectifier and the magnet. At his mode of switching the tripping delay is short, since the energy of the magnetic field is absorbed by the rectifier. The voltage peaks that occur at switching are limited to a harmless level for the rectifier.

The maximal permissible switching frequency for the DC-side switching of rectifiers depends on the energy content of the magnet for **COMBISTOP**. Higher switching frequencies are achieved by the external connection of a varistor in parallel to the brake or to the terminals + and - DC of the rectifier.

Rectifier	KEB-article	varistor
02.91.	00.90.045-2752	S20K275
04.91.	00.90.045-6251	S20K625
05.91.	00.90.045-6251	S20K625
06.91.	00.90.045-4202	S20K420*

* 2 components in series

Current-time-/Voltage-time-/Torque-time- diagram

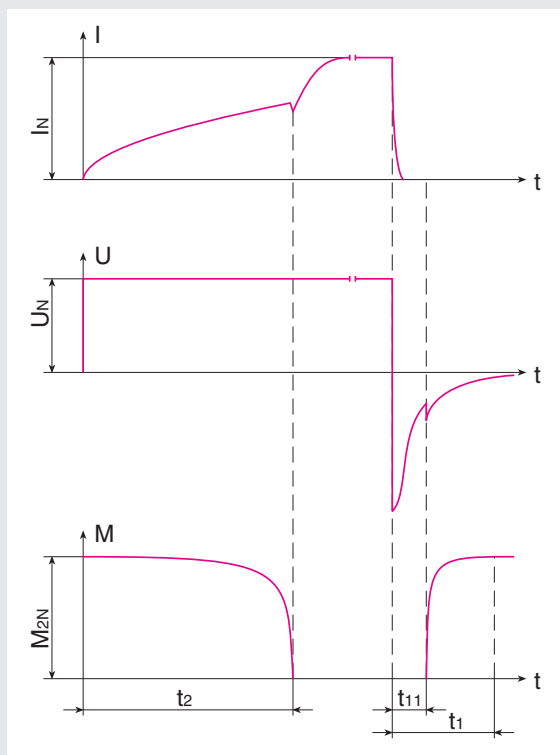

Wiring diagram

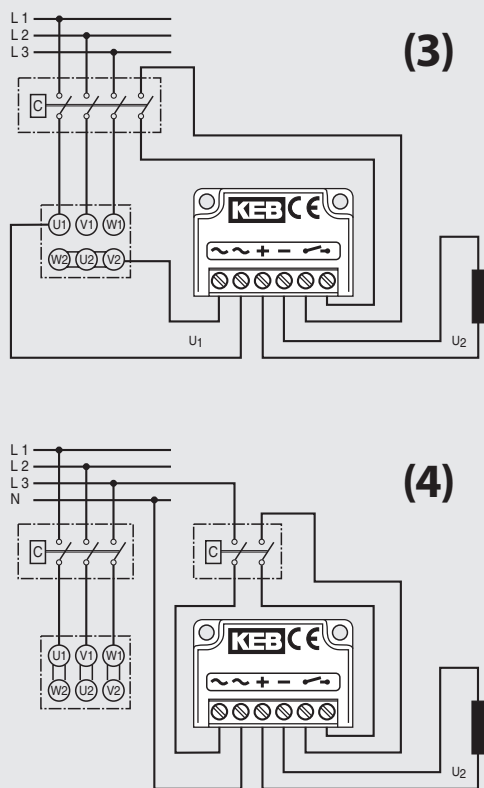

The simultaneous AC and DC-side switching, shown in example **4** guarantees short disconnecting times and reduces the contact erosion.

Dimensioning / Calculations

Decisive for the dimensioning of the clutches and brakes are the required torque, thermal load, braking time and service life.

Rated Torque M_{2N}

To ensure that brakes and clutches work safely even under extreme conditions, the required torque must be multiplied by a safety factor. The selection of the safety factor depends essentially on the application.

The dynamic torque of a single-disc brake may be substantially lower than the rated torque. When choosing the sign take into account whether the load torque supports or counteracts the deceleration.

$$M_{2N} = M_{\text{erf}} \cdot K$$

$$K \geq 2$$

$$M_{\text{erf}} = \text{required torque [Nm]}$$

Required torque M_{erf}

The required torque very often is a mixture of dynamic and static load. When choosing the sign take into account whether the load torque supports or counteracts the deceleration.

$$M_{\text{erf}} = M_A \pm M_L$$

$$M_A = J \cdot \alpha$$

Rough definition of the required braking torque

If the mass moment of inertia is unknown and the driving power is fixed then the required braking torque is calculated as follows:

$$M_{\text{erf}} = 9550 \cdot \frac{P}{n}$$

Thermal load

The dimensioning solely on the basis of the required braking torque is permissible only in very few cases. When decelerating the load and the mass moment of inertia is reduced to the brake shaft, the kinetic energy is converted into heat (friction work of the brake). The permissible friction work in dependence on the switching frequency may not be exceeded. Please note that the maximal permissible friction work is valid only up to the corresponding speed. In case of emergency stop from maximum speed the maximal permissible friction work lies considerably below the values specified in the graphic.

$$W_R = \frac{J \cdot n^2}{182,5} \cdot \frac{M_{2N}}{M_{2N} \pm M_L} \quad W_R \leq W_{R\text{max}}$$

Slip time t_3 [ms]

The time from the beginning of the torque rise until attaining the moment of synchronization.

$$t_3 = 104,6 \cdot \frac{J \cdot \Delta n}{M_{2N} \pm M_L} + t_{11}$$

Service life

The service life depends to a large extent on the peak temperature at braking, which is dependent on the speed, the deceleration time and the current brake torque. For that reason it is not possible to make universally valid statements with regard to the service life that apply to all operating conditions. Statements to the individual case can be made only when all operating conditions are known. At no time should the friction lining thickness be less than g_{min} .

$$L_N = \frac{(X_n - X) \cdot W_{R0,1}}{0,1 \cdot W_R}$$

Acceleration- / Deceleration time

$$t = \frac{J \cdot \omega}{M_{2N} \pm M_L} + t_1$$

people in motion



KEB Antriebstechnik Austria GmbH • Ritzstraße 8 • **A** - 4614 Marchtrenk
Tel.: +43 7243 53586-0 • FAX: +43 (0) 7243 53586-21
Internet: www.keb.at • E-Mail: info@keb.at



KEB Antriebstechnik Austria GmbH / Organizacni slozka • K. Weise 1675/5 • **CZ** - 37004 České Budějovice
Tel.: +420 38 76991-11 • FAX: +420 38 76991-19
Internet: www.keb.at • E-Mail: info@seznam.cz



KEB Antriebstechnik • Herenveld 2 • **B** - 9500 Geraardsbergen
Tel.: +32 5443 7860 • FAX: +32 5443 7898
E-Mail: vb.belgien@keb.de



KEB Power Transmission Technology (Shanghai) Co., Ltd.
No. 435 QianPu Road, Songjiang East Industrial Zone • CN-201611 Shanghai, PR.China
Tel.: +86 21 37746688 • Fax: +86 21 37746600 • Internet: www.keb.cn • E-mail: info@keb.cn



Société Française KEB • Z.I. de la Croix St. Nicolas • 14, rue Gustave Eiffel • **F** - 94510 LA QUEUE EN BRIE
Tél.: +33 1 49620101 • FAX: +33 1 45767495
Internet: www.keb.fr • E-Mail: info@keb.fr



KEB (UK) Ltd. • 6 Chieftain Buisness Park, Morris Close • Park Farm, Wellingborough, **GB** - Northants, NN8 6 XF
Tel.: +44 1933 402220 • FAX: +44 1933 400724
Internet: www.keb-uk.co.uk • E-Mail: info@keb-uk.co.uk



KEB Italia S.r.l. • Via Newton, 2 • **I** - 20019 Settimo Milanese (Milano)
Tel.: +39 02 33535311 • FAX +39 02 33500790
Internet: www.keb.it • E-Mail: info@keb.it



KEB - Japan Ltd. • 15 - 16, 2-Chome • Takanawa Minato-ku • **J** - Tokyo 108 - 0074
Tel.: +81 33 445-8515 • FAX: +81 33 445-8215
Internet: www.keb.jp • E-Mail: info@keb.jp



KEB KOREA • Representative Office, Room 1709, 415 Missy 2000, 725 Su Seo Dong, Gang Nam Gu
ROK - 135-757 Seoul / South Korea
Tel.: +82 2 6253-6771 • FAX: +82 (0) 2 6253-6770 • Internet: www.kebkorea.com • E-Mail: vb.korea@keb.de



KEB - RUS Ltd. • Lesnaya Str., house 30 Dzerzhinsky (MO) • **RUS** - 140091 Moscow region
Telefon + 7 495 5508367 • Telefax +7 495 6320217
E-Mail: info@keb.ru • Internet: www.keb.ru



KEB Sverige • Box 265 (Tjolvmenvägen 34) • **S** - 47512 Hälsö
Tel.: +46 31 961520 • FAX: +46 31 961124
E-Mail: vb.schweden@keb.de



KEB España • C / Mitjer, Nave 8 Poligono Industrial "La masia" • **E** - 08798 Sant Cugat Ssegarrigues (Barcelona)
Tel.: +34 93 8970268 • FAX: +34 93 8992035
E-Mail: vb.espana@keb.de



KEB America, Inc. • 5100 Valley Industrial Blvd. South • **USA** - Shakopee, MN 55379
Tel.: +1 952 2241400 • FAX: +1 952 2241499
Internet: www.kebamerica.com • E-Mail: info@kebamerica.com



KEB Antriebstechnik GmbH • Wildbacher Str. 5 • **D** - 08289 Schneeberg
Telefon +49 3772 67-0 • Telefax +49 3772 67-281
Internet: www.keb.de • E-Mail: info@keb-combidrive.de

© KEB 00.00.000-5MAG 08/2010- Subject to technical changes -



Karl E. Brinkmann GmbH
Försterweg 36 - 38 • D - 32683 Barntrup
Telefon 0 52 63 / 4 01 - 0 • Telefax 4 01 - 116
Internet: www.keb.de • E-mail: info@keb.de